

# Technical regulation 3.2.1 for power plants up to and including 11 kW

(Plant category A1)

Applicable for grid connections prior to 27. April 2019

2	Published UK edition	22.06.2016	29.06.2016	29.06.2016	29.06.2016	DATE
		KDJ	FBN	BJA	APJ	NAME
REV.	DESCRIPTION	PREPARED	CHECKED	REVIEWED	APPROVED	
		<b>15/01353-94</b>				

## Revision view

Section no.	Text	Revision	Date
All sections	<p>The regulation was amended based on consultation comments received.</p> <p>Section 1.2.33 added.</p> <p>The term '<i>electricity-generating plant</i>' was changed to '<i>plant</i>' in line with other regulations.</p> <p>Section 5 was reorganised to follow the structure in the other technical regulations.</p>	2	30.06.2016
Section 8 and Appendix 1	<p>Consultation document – submitted for a new public consultation due to changes in responsibilities related to positive lists. (Document not available in English).</p>	1	03.06.2016
All sections	<p>Various minor changes and proofing corrections.</p>		
All sections	<p>Consultation document – submitted for public consultation. (Document not available in English).</p> <p>The consultation document was created in a new template based on an earlier version of the regulation (doc. 35198/10, version 2.1)</p>	0	30.09.2015

## Table of contents

Revision view.....	2
Table of contents.....	3
List of figures and tables .....	4
Reading instructions .....	5
1. Terminology, abbreviations and definitions .....	6
2. Objective, scope of application and regulatory provisions.....	16
3. Tolerance of frequency and voltage deviations .....	22
4. Power quality .....	24
5. Control and regulation.....	26
6. Protection.....	37
7. Data communication and exchange of signals .....	40
8. Verification and documentation .....	41
Appendix 1 Documentation.....	43

## List of figures and tables

### List of figures:

Figure 1	Definition of sign for active power, reactive power, Power Factor set points and reference for Power Factor angle. ....	9
Figure 2	Example of installation connection of a plant. ....	12
Figure 3	Example of grid connection of a plant. ....	13
Figure 4	Active power requirements in the event of frequency and voltage fluctuations for plants in category A1. ....	23
Figure 5	Frequency response for a plant. ....	28
Figure 6	Drawing of constraint functions for active power. ....	28
Figure 7	Reactive power control functions for a plant. ....	30
Figure 8	Power Factor (PF) control for a plant. ....	31
Figure 9	Automatic Power Factor control for a plant. ....	32
Figure 10	Requirements for the delivery of reactive power as a function of active power $P/S_n$ for category A1 plants. ....	35
Figure 11	Requirements for the delivery of reactive power as a function of the voltage in the POC for category A1 plants [ref. 21]. ....	36
Figure 12	Overview of a plant with integrated grid protection in each unit. ...	38

### List of tables:

Table 1	Nominal, minimum and maximum voltage [ref. 1 and ref. 4].....	22
Table 2	Overview of power quality requirements for plant category A1. ...	24
Table 3	Control functions for plants – A1.....	26
Table 4	Active power control functions – A1. ....	33
Table 5	Reactive power control functions – A1. ....	34
Table 6	Protective function requirements for plants in category A1. ....	39
Table 7	Requirements for information exchange with a category A1 plant. ....	40
Table 8	Documentation requirements for plant category A1.....	41

## Reading instructions

This regulation contains the technical and functional minimum requirements which *plants* with a *rated power* of up to and including 11 kW (*plant category* A1) must comply with if they are to be connected to the Danish grid.

The regulation is structured so that section 1 outlines the terminology and definitions used; section 2 describes the regulatory provisions and relevant references, while the technical and functional requirements are described in sections 3, 4, 5, 6 and 7. Section 8 contains the documentation requirements for *plant category* A1.

The regulation makes extensive use of terminology and definitions. The key ones are defined in section 1.

In the regulation, terminology and definitions are written in *italics*.

The regulation is also published in English. In case of doubt, the Danish version applies.

The regulation is published by the *transmission system operator* and is available at [www.energinet.dk](http://www.energinet.dk).

# 1. Terminology, abbreviations and definitions

## 1.1 Abbreviations

This section contains the abbreviations used in the document.

### 1.1.1 $df/dt$

$df/dt$  denotes the frequency change as a function of time. See section 6.2 for a more detailed description.

### 1.1.2 $f_{<}$

$f_{<}$  denotes the operational setting for underfrequency in the relay protection. See section 6.2 for a more detailed description.

### 1.1.3 $f_{>}$

$f_{>}$  denotes the operational setting for overfrequency in the relay protection. See section 6.2 for a more detailed description.

### 1.1.4 $f_R$

$f_R$  denotes the frequency at which a *plant* is to begin downward regulation with the agreed *droop*. See section 5.2.1 for a more detailed description.

### 1.1.5 $I_n$

The *rated current*  $I_n$  is the maximum continuous current that a *plant* or an *electricity-generating unit* is designed to deliver. See section 1.2.35 for a more detailed description.

### 1.1.6 $I_Q$

The reactive current delivered or absorbed by a *plant* is referred to as  $I_Q$ .

### 1.1.7 $P_M$

$P_M$  indicates the active power which can be generated under the given circumstances.

### 1.1.8 $P_n$

$P_n$  denotes the *rated power of a plant*. See section 1.2.36 for a more detailed description.

### 1.1.9 PCC

*Point of Common Coupling (PCC)*. See section 1.2.22 for a more detailed description.

### 1.1.10 PCI

*Point of Connection in Installation (PCI)* is the point in the installation where the *plant* is connected and where consumption is connected. See section 1.2.25 for a more detailed description.

### 1.1.11 PCOM

*Point of Communication (PCOM)*. See section 1.2.23 for a more detailed description.

**1.1.12 PF**

*Power Factor (PF)*. See section 1.2.28 for a more detailed description.

**1.1.13 PGC**

*Point of Generator Connection (PGC)* is the point defined by the supplier of an *electricity-generating unit* as the *unit's* terminals. See section 1.2.26 for a more detailed description.

**1.1.14 POC**

*Point of Connection (POC)*. See section 1.2.24 for a more detailed description.

**1.1.15  $U_c$** 

$U_c$  denotes the *normal operating voltage*. See section 1.2.14 for a more detailed description.

**1.1.16  $U_{max}$** 

$U_{max}$  denotes the maximum value of the *nominal voltage*  $U_n$  that a *plant* may be exposed to.

**1.1.17  $U_{min}$** 

$U_{min}$  denotes the minimum value of the *nominal voltage*  $U_n$  that a *plant* may be exposed to.

**1.1.18  $U_n$** 

$U_n$  denotes the *nominal voltage*. The voltage is measured phase to phase. See section 1.2.13 for a more detailed description.

**1.1.19  $U_{PGC}$** 

$U_{PGC}$  denotes the voltage measured on the *electricity-generating unit's* terminals. See section 1.2.26 for a more detailed description.

**1.1.20  $U_{POC}$** 

$U_{POC}$  denotes the *normal operating voltage* in the *POC*. See section 1.2.24 for a more detailed description.

**1.1.21  $U_x$** 

$U_x$  where x indicates the relay configuration for undervoltage steps 1 (<) or 2 (<<) as well as overvoltage steps 1 (>), 2 (>>) or 3 (>>>). See section 6.2 for a more detailed description.

## 1.2 Definitions

This section contains the definitions used in the document. Several definitions are based on IEC 60050-415:1999, but have been modified for the purpose.

### 1.2.1 Absolute power constraint

Adjustment of active power to a maximum level is indicated by a set point. The +/- tolerance of the set point adjustment is referred to as the *absolute power constraint*. See section 5.2.2.1 for a more detailed description.

### 1.2.2 Balance-responsible party for production

A *balance-responsible party for production* is financially accountable to the *transmission system operator*.

The *balance-responsible party for production* holds the balance responsibility for a given plant vis-à-vis the *transmission system operator*.

### 1.2.3 Droop

*Droop* is the angle of a curve which a control function must follow.

### 1.2.4 Electricity-generating unit

An *electricity-generating unit* is a unit which generates electricity, and which is directly or indirectly connected to the *public electricity supply grid*.

### 1.2.5 Electricity supply undertaking

The *electricity supply undertaking* is the enterprise to whose grid a *plant* is connected electrically. Responsibilities in the *public electricity supply grid* are distributed onto several *grid companies* and one *transmission enterprise*.

The *grid company* is the company licensed to operate the *public electricity supply grid up to* 100 kV.

The *transmission enterprise* is the enterprise licensed to operate the *public electricity supply grid above* 100 kV.

### 1.2.6 Emergency power unit

An *emergency power unit* is a unit connected to an installation for the purpose of supplying electricity in situations where the *public electricity supply grid* is unable to supply electricity.

### 1.2.7 Flicker

*Flicker* is a visual perception of light flickering caused by *voltage fluctuations*. *Flicker* occurs if the luminance or the spectral distribution of light fluctuates with time. At a certain intensity, *flicker* becomes an irritant to the eye.

### 1.2.8 Frequency response

*Frequency response* is the automatic downward regulation of active power as a function of grid frequencies above a certain frequency  $f_R$  with a view to stabilising the grid frequency. See section 5.2.1 for a more detailed description.



**1.2.9 Generator convention**

The sign for active/reactive power indicates the power flow seen from the generator. The consumption/import of active/reactive power is indicated by a negative sign, while the generation/export of active/reactive power is indicated by a positive sign.

The sign of the *Power Factor* set point is used to determine whether control should take place in the first or the fourth quadrant. For *Power Factor* set points, two pieces of information are thus combined into a single signal: A set point value and the choice of control quadrant.

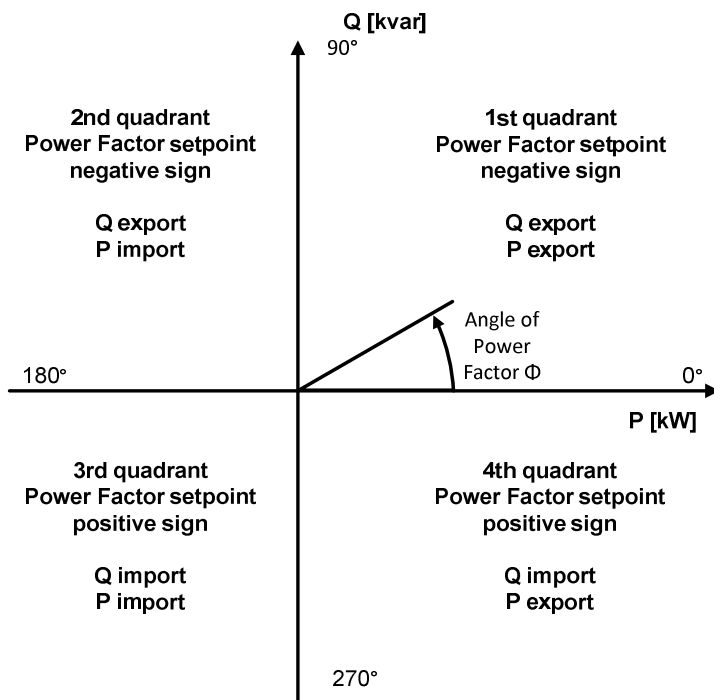

Figure 1 Definition of sign for active power, reactive power, Power Factor set points and reference for Power Factor angle.

**1.2.10 Grid company**

A licensed company which operates the distribution grid. The *grid company* is the enterprise to whose grid a *plant* has been connected electrically.

**1.2.11 Harmonic distortions**

*Harmonic distortions* are defined as electrical disturbances caused by overharmonic currents and voltages. *Harmonic distortions* are also referred to as overtones, overharmonic tones, overharmonic distortion or simply harmonics.

**1.2.12 Limiting component**

The *limiting component* is the component in a *plant* which defines/limits the *rated power of the plant*.

For example, a *plant owner* can install solar panels larger than the active power limit for a specific *plant category* if the inverter is limited to and sealed at a

maximum active power output corresponding to the category in which the *plant* is to be placed. In this case, the inverter is the *limiting component*. For wind turbines or other generator types, the *limiting component* could be power electronics, a subsystem or the control unit which controls the active power output from the *plant*.

### 1.2.13 Nominal voltage ( $U_n$ )

The voltage at the *POC* which defines a grid and to which operational characteristics are referred. The voltage is measured phase to phase. *Nominal voltage* is denoted by  $U_n$ .

The internationally standardised voltage levels are shown in Table 1.

### 1.2.14 Normal operating voltage ( $U_o$ )

*Normal operating voltage* indicates the voltage range within which a *plant* must be able to continuously generate the specified *rated power*, see sections 3.1 and 3.2. *Normal operating voltage* is determined by the *electricity supply undertaking* and is used to determine the *normal production* range.

### 1.2.15 Normal production

*Normal production* indicates the voltage/frequency range within which a *plant* must be able to continuously generate the specified *rated power*, see sections 3.1 and 3.2.

### 1.2.16 Plant

A *plant* consists of one or more *electricity-generating units*, which are defined in more detail in section 1.2.4. *The plant* is connected to the *public electricity supply grid* through one *Point of Connection*.

### 1.2.17 Plant categories

*Plant categories* in relation to the total *rated power* in the *Point of Connection*:

- A1. *Plants* up to and including 11 kW
- A2. *Plants* above 11 kW up to and including 50 kW
- B. *Plants* above 50 kW up to and including 1.5 MW
- C. *Plants* above 1.5 MW up to and including 25 MW
- D. *Plants* above 25 MW or connected to over 100 kV.

### 1.2.18 Plant component

A *plant component* is a component or subsystem which is part of an overall *plant*.

### 1.2.19 Plant infrastructure

The *plant infrastructure* is the electrical infrastructure between the *Point of Generator Connection (PGC)* of the individual *electricity-generating units* in a *plant* and up to the *Point of Connection (POC)*.

### 1.2.20 Plant operator

The *plant operator* is the enterprise responsible for the operation of a *plant*, either through ownership or contractual obligations.

### 1.2.21 Plant owner

The *plant owner* is the legal owner of a *plant*. In certain situations, the term company is used instead of *plant owner*. The *plant owner* is entitled to hand over the operational responsibility to a *plant operator*.

### 1.2.22 Point of Common Coupling (PCC)

The *Point of Common Coupling (PCC)* is the point in the *public electricity supply grid*, where consumers are or can be connected.

The *Point of Common Coupling* and the *Point of Connection* may coincide electrically. The *Point of Common Coupling (PCC)* is always located farthest into the *public electricity supply grid*, i.e. farthest away from the *plant*, see Figure 2 and Figure 3.

The *electricity supply undertaking* determines the *Point of Common Coupling*.

### 1.2.23 Point of Communication (PCOM)

The *Point of Communication (PCOM)* is the point in a *plant*, where the data communication properties specified in section 7 must be made available and verified.

### 1.2.24 Point of Connection (POC)

The *Point of Connection (POC)* is the point in the *public electricity supply grid*, where the *plant* is or can be connected, see Figure 2 and Figure 3.

All requirements specified in this regulation apply to the *Point of Connection*. By agreement with the *electricity supply undertaking*, reactive compensation at no load can be placed elsewhere in the *public electricity supply grid*. The *electricity supply undertaking* determines the *Point of Connection*.

Figure 2 shows a typical installation connection of one or more *plants* indicating the typical locations of the *Point of Generator Connection (PGC)*, *Point of Connection (POC)*, *Point of Connection in Installation (PCI)* and the *Point of Common Coupling (PCC)*. In the example shown, the *Point of Common Coupling (PCC)* and the *Point of Connection (POC)* coincide.

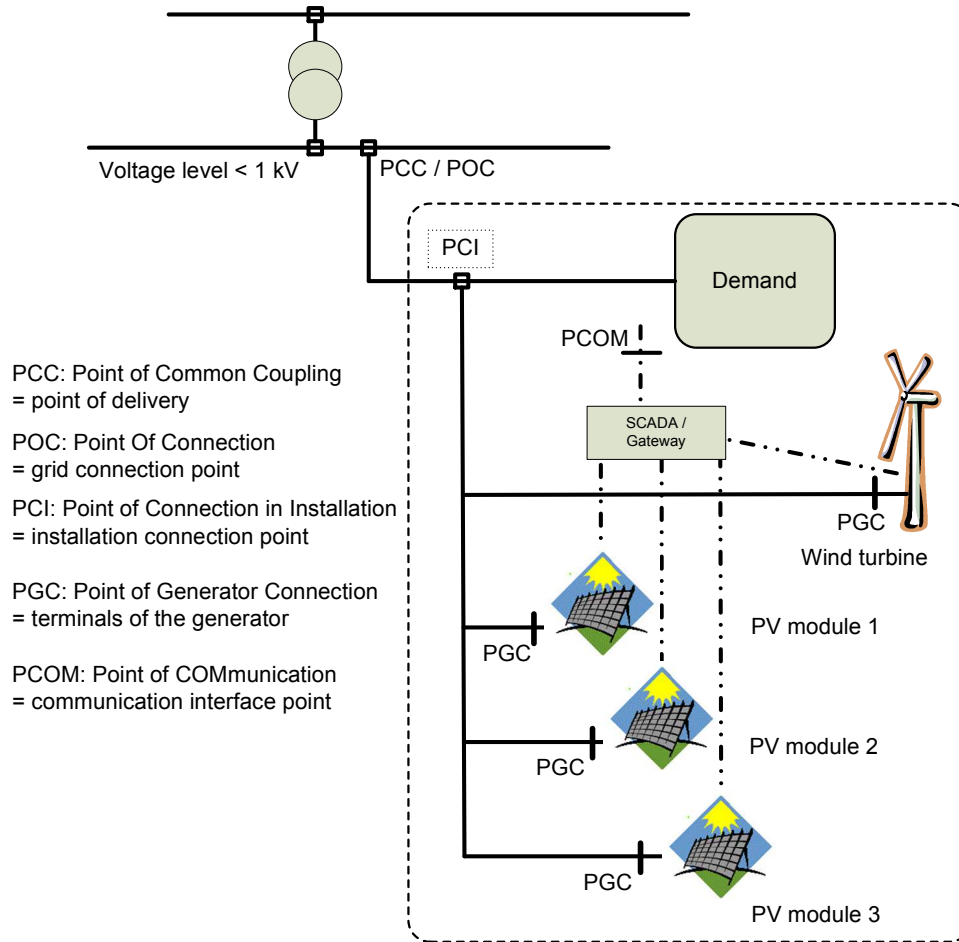

Figure 2 Example of installation connection of a plant.

Figure 3 shows a typical grid connection of several *plants* indicating where the *Point of Generator Connection (PGC)*, *Point of Connection (POC)*, *Point of Common Coupling (PCC)* and the voltage reference point can be located. The voltage reference point is either in the *Point of Connection (POC)*, the *Point of Common Coupling (PCC)* or a point in between.

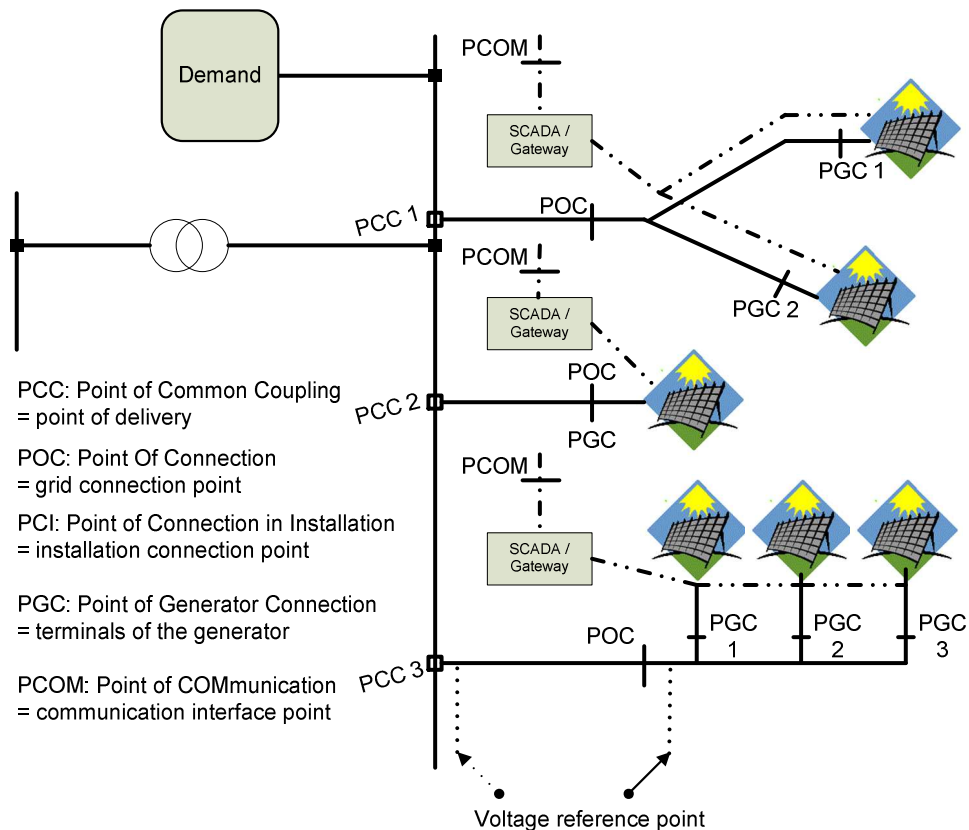

Figure 3 Example of grid connection of a plant.

**1.2.25 Point of Connection in Installation (PCI)**

The *Point of Connection in Installation (PCI)* is the point in the installation where *electricity-generating units* in the installation are connected or can be connected, see Figure 2 for the typical location.

**1.2.26 Point of Generator Connection (PGC)**

The *Point of Generator Connection* is the point in the *plant infrastructure*, where the terminals/generator terminals for the *electricity-generating unit* are located. The *Point of Generator Connection* for a *plant* is the point defined by the manufacturer as the *electricity-generating unit's* terminals.

**1.2.27 Positive list**

A so-called *positive list* has been prepared to facilitate the technical approval process for grid connection of category A1 and A2 *plants*. The list contains *plant components* deemed to comply with the specific property and functionality requirements under the relevant technical regulations.

The *positive list* is available at the Danish Energy Association's website: [www.danskeenergi.dk/positivlister](http://www.danskeenergi.dk/positivlister).

**1.2.28 Power Factor (PF)**

The *Power Factor*, cosine  $\phi$ , for AC voltage systems indicates the ratio of the active power P to the apparent power S, where  $P = S \cdot \cos \phi$ . Likewise, the reactive power  $Q = S \cdot \sin \phi$ . The angle between current and voltage is denoted by  $\phi$ .

### 1.2.29 Power Factor control

*Power Factor control* is the control of the reactive power proportionately to the active power generated. See section 5.3.2 for a more detailed description.

### 1.2.30 Power infrastructure

The *power infrastructure* is the part of the *public electricity supply grid* that connects the *POC* and *PCC*.

### 1.2.31 Public electricity supply grid

Transmission and distribution grids, the purpose of which is to transmit electricity for an indefinite group of electricity suppliers and consumers on terms laid down by public authorities.

The distribution grid is defined as the *public electricity supply grid* with a **maximum nominal voltage** of 100 kV.

The transmission grid is defined as the *public electricity supply grid* with a **nominal voltage above** 100 kV.

### 1.2.32 Q control

*Q control* is the control of the reactive power independent of the active power generated.

### 1.2.33 Ramp rate constraint

*Ramp rate constraint* is a function controlling the interval of active power with a set point-defined maximum increase/reduction (*ramp rate*) of the active power. See section 5.2.2.2 for a more detailed description.

### 1.2.34 Rapid voltage changes

*Rapid voltage change* is defined as a brief isolated voltage change (RMS). *Rapid voltage changes* are expressed as a percentage of *normal operating voltage*.

### 1.2.35 Rated current ( $I_n$ )

*Rated current  $I_n$*  is defined as the maximum continuous current that a *plant* is designed to provide under normal operating conditions. *Rated current* is denoted by  $I_n$ .

### 1.2.36 Rated power of a plant ( $P_n$ )

The *rated power of a plant* is the highest level of active power that the *plant* is designed to continuously provide and which appears from the type approval. The *rated power* is denoted by  $P_n$ .

### 1.2.37 Transmission enterprise

Enterprise licensed to operate the transmission grid. The *transmission enterprise* is the enterprise in whose grid the distribution grid, or the *plant*, is electrically connected.

### 1.2.38 Transmission system operator

Enterprise entrusted with the overall responsibility for maintaining security of supply and ensuring effective utilisation of the *public electricity supply grid*.

### **1.2.39 Voltage fluctuation**

*Voltage fluctuation* is a series of *rapid voltage changes* or a periodic variation of the root-mean-square (RMS) value of the voltage.

## 2. Objective, scope of application and regulatory provisions

### 2.1 Objective

The objective of Technical regulation 3.2.1 is to specify the minimum technical and functional requirements that a *plant* with a *rated power* up to and including 11 kW must comply with in the *Point of Connection* when the *plant* is connected to the *public electricity supply grid*.

### 2.2 Scope of application

A *plant* connected to the *public electricity supply grid* must throughout its life-time comply with the provisions of this regulation.

The technical requirements of the regulation have been defined for the following category based on the total *rated power* in the *Point of Connection*:

#### A1. Plants up to and including 11 kW

For planning and grid expansion reasons, the *electricity supply undertaking* has the right to reject grid connection for any *plant* which is not three-phase.

The specific *plant category*, as described in section 1.2.17, is defined in relation to the possible active power generation in the *POC*. If there are several *PCIs* under the same installation, the total possible active power generation summed for all points will apply. The *plant category* size is thus determined by the *limiting component* in the *plant*. For example, in solar power and wind turbine *plants*, the *limiting component* is typically the inverter or other form of power electronics which controls the active power output from the *plant*.

All requirements in this regulation respect the *plant's* design framework that the current technology offers, including properties under different operating conditions.

#### 2.2.1 New plants

This regulation applies to all *plants* with *rated power* up to and including 11 kW connected to the *public electricity supply grid* and commissioned as of the effective date of this regulation.

#### 2.2.2 Existing plants

A *plant* with *rated power* up to and including 11 kW which was connected to the *public electricity supply grid* before the effective date of this regulation must comply with the regulation in force at the time of commissioning.

#### 2.2.3 Modifications to existing plants

If substantial functional modifications are made to an existing *plant*, the *plant* must comply with the provisions of this regulation relating to such modifications. Before modifications are made, the *plant owner* must inform the *electricity supply undertaking* of the modification to the *plant*. A substantial modification could be the replacement of one or more vital *plant components* which changes the properties of the *plant*.



In case of doubt, the *transmission system operator* decides whether a specific modification is substantial.

Connection of a *plant* which has previously been installed at another location requires a new grid connection agreement. The *plant* must therefore meet the requirements for new *plants* described in this technical regulation.

The documentation described in section 8 must be updated and submitted in a version showing any modifications made.

### 2.3 Delimitation

This technical regulation is part of the complete set of technical regulations issued by the Danish *transmission system operator*, Energinet.dk.

The regulation uses specifications in the EN50438 European standard [ref. 3], where relevant, and thus contributes to harmonising the rules for grid connection of *plants* in Europe.

*Plants* must comply with Danish legislation, including:

- Section 6 of the Danish Heavy Current Regulation: 'Electrical installations', 2003 [ref. 6]
- Section 2 of the Danish Heavy Current Regulation: 'Design of electricity supply systems', 2003 [ref. 7]
- Joint Regulation 2014: 'Connection of electrical equipment and utility products' [ref. 5]
- DS/EN 60204-1:2006: 'Danish Heavy Current Regulation Safety of machines – Electrical equipment of machines' [ref. 8]
- DS/EN 60204-11:2002: 'Safety of machinery – Electrical equipment of machines – Part 11: Requirements for HV equipment for voltages above 1000 V a.c. or 1500 V d.c. and not exceeding 36 kV' [ref. 9]
- The grid connection and grid use agreement.

In areas which are not subject to Danish legislation, CENELEC standards (EN), IEC standards and CENELEC or IEC technical specifications apply.

Together with the market regulations, the technical regulations (including the system operation regulations) constitute the set of rules which the *plant owner*, *plant operator* and *electricity supply undertaking* must comply with during operation of a *plant*:

- Technical regulation TR 5.8.1 'Metering data for system operation purposes' [ref. 10]
- Technical regulation TR 5.9.1 'Ancillary services' [ref. 11]
- Regulation D1 'Settlement metering' [ref. 12]
- Regulation D2 'Technical requirements for electricity metering' [ref. 13]
- Regulation E 'Settlement of environmentally-friendly electricity generation' [ref. 14]
- Technical regulation TR 3.2.1 'Technical regulation for power plants up to and including 11 kW'.

In case of discrepancies between the requirements of the individual regulations, the *transmission system operator* decides which requirements should apply.

Current versions of the above-mentioned documents are available on Energinet.dk's website [www.energinet.dk](http://www.energinet.dk).

Operational matters will be agreed between the *plant owner* and the *electricity supply undertaking* within the framework set by the *transmission system operator*.

The regulation does not set requirements for *emergency power units* as long as they are not operated in parallel with the *public electricity supply grid* for more than five minutes per month. Parallel operation in connection with unit maintenance or commissioning testing is not included in the five minutes [ref. 20]. However, the *emergency power unit* must fulfil the protection requirements described in section 6 of this regulation. The unit must also meet the general *emergency power unit* requirements described in section 6 of the Danish Heavy Current Regulation: 'Electrical installations', 2003 [ref. 6].

This regulation does not deal with the financial aspects of using control capabilities, settlement metering or technical requirements for settlement metering.

The *plant owner* is responsible for safeguarding the *plant* against possible damaging impacts due to a lack of electricity supply from the *public electricity supply grid* for shorter or longer periods of time.

#### **2.4 Statutory authority**

The regulation is issued pursuant to Section 7(1) (i), (iii) and (iv) of Danish Executive Order no. 891 of 17 August 2011 (Executive Order on transmission system operation and the use of the electricity transmission grid, etc. (Systemansvarsbekendtgørelsen)). Under Section 7(1) of the Executive Order on transmission system operation and the use of the electricity transmission grid, etc., this regulation has been prepared following discussions with players and *grid companies*. It has also been subject to public consultation before being registered with the Danish Energy Regulatory Authority.

This regulation is effective within the framework of the Danish Electricity Supply Act (Elforsyningsloven), see Consolidated Act no. 1329 of 25 November 2013 as amended.

#### **2.5 Effective date**

This regulation comes into force on **30 June 2016** and replaces:

- Technical regulation 3.2.1 for electricity-generating plants with a rated current of 16 A per phase or less, revision 2.1, effective from 1 January 2012.

Questions and requests for additional information on this technical regulation can be directed to Energinet.dk.

Contact information is available at [www.energinet.dk](http://www.energinet.dk).

The regulation was registered with the Danish Energy Regulatory Authority pursuant to the provisions of Section 26 of the Danish Electricity Supply Act (Elforsyningsloven) and Section 7 of the Danish Executive Order on transmis-

sion system operation and the use of the electricity transmission grid, etc. (Systemansvarsbekendtgørelsen).

As regards *plants*, the construction of which was finally ordered in a binding written order before the regulation was registered with the Danish Energy Regulatory Authority, but which are scheduled to be commissioned after this regulation comes into force, an exemption can be applied for in accordance with section 2.9, enclosing any relevant documentation.

## 2.6 Complaints

Complaints in respect of this regulation may be lodged with the Danish Energy Regulatory Authority, [www.energitilsynet.dk](http://www.energitilsynet.dk).

Complaints about the *transmission system operator's* enforcement of the provisions of the regulation can also be lodged with the Danish Energy Regulatory Authority.

Complaints about how the individual *electricity supply undertaking* enforces the provisions of the regulation can be lodged with the *transmission system operator*.

## 2.7 Breach

The *plant owner* must ensure that the provisions of this regulation are complied with throughout the lifetime of the *plant*.

The *plant* must be subjected to regular maintenance checks to ensure that the provisions of this regulation are complied with.

The *plant owner* must pay any expenses incurred to ensure compliance with the provisions of this regulation.

## 2.8 Sanctions

If a *plant* does not comply with the provisions of section 3 and onwards of this regulation, the *electricity supply undertaking* is entitled as a last resort to cut off the electrical connection to the *plant* until the provisions are complied with.

## 2.9 Exemptions and unforeseen events

The *transmission system operator* may grant exemption from specific requirements in this regulation.

An exemption can only be granted if:

- special conditions exist, for instance of a local nature
- the deviation does not impair the technical quality and balance of the *public electricity supply grid*
- the deviation is not inappropriate from a socio-economic viewpoint.

In order to obtain an exemption, a written application must be submitted to the *electricity supply undertaking*, stating which provisions the exemption concerns and the reason for the exemption.

The *electricity supply undertaking* has the right to comment on the application before it is submitted to the *transmission system operator*.

If events not foreseen in this technical regulation occur, the *transmission system operator* must consult the parties involved to reach an agreement on the course of action.

If an agreement cannot be reached, the *transmission system operator* must decide on the course of action.

The decision must be based on what is reasonable, where possible taking the views of the parties involved into consideration.

Complaints about the decisions of the *transmission system operator* can be lodged with the Danish Energy Regulatory Authority, see section 2.6.

## 2.10 References

The mentioned International Standards (IS), European Standards (EN), Technical Specifications (TS) and Technical Reports (TR) are only to be used within the topics mentioned in connection with the references in this regulation.

### 2.10.1 Normative references

1. **DS/EN 50160:2010:** Voltage characteristics of electricity supplied by public distribution networks.
2. **DS/EN 50160:2010/A1:2015:** Addendum to voltage characteristics of electricity supplied by public distribution networks.
3. **DS/EN 50438:2013:** Requirements for micro-generating plants to be connected in parallel with public low-voltage distribution networks, 2013.
4. **DS/EN 60038:2011:** CENELEC standard voltages.
5. **Joint Regulation 2014:** 'Connection of electrical equipment and utility products'.
6. **Section 6 of the Danish Heavy Current Regulation:** 'Electrical installations', 2003.
7. **Section 2 of the Danish Heavy Current Regulation:** 'Design of electricity supply systems', 2003.
8. **DS/EN 60204-1:2006:** Danish Heavy Current Regulation Safety of machines – Electrical equipment of machines.
9. **DS/EN 60204-11:2002:** Safety of machinery – Electrical equipment of machines – Part 11: Requirements for HV equipment for voltages above 1000 V a.c. or 1500 V d.c. and not exceeding 36 kV.
10. **Technical regulation TR 5.8.1:** 'Måledata til systemdriftsformål' (Metering data for system operation purposes), dated 28 June 2011, Rev. 3.0, document no. 17792/10 (= new doc. no. 13/89692-218).
11. **Technical regulation TR 5.9.1:** 'Systemtjenester' (Ancillary services), dated 5 July 2012, Rev. 1.1, document no. 91470-11 (= new doc. no. 13/89692-225).
12. **Regulation D1:** 'Settlement metering', March 2016, version 4.11, document no. 16/04092-18.
13. **Regulation D2:** 'Technical requirements for electricity metering', May 2007, Rev. 1, document no. 171964-07 (= new doc. no. 13/91893-11).

14. **Regulation E:** 'Miljøvenlig elproduktion og anden udligning 2009' (Settlement of environmentally-friendly electricity generation 2009), July 2009, rev. 1, document no. 255855-06.
15. **IEC/TR 61850-90-7 Ed1.0:2013:** Object models for power converters in distributed energy resources (DER) systems.
16. **DS/EN 61000-3-2:2014:** Limit values – Limit values for harmonic current emissions (equipment input current up to and including 16A per phase).
17. **DS/EN 61000-3-3:2013:** Limit values – Limitation of voltage changes, voltage fluctuations and flicker in public low-voltage supply systems, from equipment with a rated current  $\leq 16$ A per phase which is not subject to conditional connection rules.
18. **IEC/TR 61000-3-15 Ed. 1.0:2011:** Limits – Assessment of low frequency electromagnetic immunity and emission requirements for dispersed generation systems in LV network.
19. **SunSpec Inverter Control specifications:** [www.sunspec.org](http://www.sunspec.org).
20. **EU Regulation 2016/631:** The regulation is also referred to as 'Network Code requirements for grid connection of all generators' – NC RfG.
21. **DS/CLC/TS 50549-1:2014:** Requirements for generating plants to be connected in parallel with a distribution network – Part 1: Generating plants larger than 16A per phase to be connected with a low voltage network.

#### 2.10.2 Informative references

22. **Research Association of the Danish Electric Utilities (DEFU) recommendation no. 16:** Voltage quality in low-voltage grids, 2nd edition, June 2001.
23. **IEEE C37.111-24:2013:** Measuring relays and protection equipment – Part 24: Common format for transient data exchange (COMTRADE) for power systems.
24. **Research Association of the Danish Electric Utilities (DEFU) report RA498:** Low-voltage installations with autogeneration. Guidelines for connecting generation plant to the grid. November 2003.

### 3. Tolerance of frequency and voltage deviations

A *plant* must be able to withstand frequency and voltage deviations in the *Point of Connection* under normal and abnormal operating conditions while not reducing the active power.

All requirements outlined in the following sections are to be considered minimum requirements for *plants* in category A1.

Normal operating conditions and abnormal operating conditions are described in section 3.2 and section 3.3 respectively.

#### 3.1 Determination of voltage level

The *electricity supply undertaking* determines the voltage level for the *plant's Point of Connection* within the voltage limits stated in Table 1.

The *normal operating voltage* may differ from location to location, and the *electricity supply undertaking* must therefore state the *normal operating voltage*  $U_c$  for the *Point of Connection*.

The *electricity supply undertaking* must ensure that the maximum voltage stated in Table 1 is never exceeded.

If the *normal operating voltage* range  $U_c - 15\%$  is lower than the minimum voltage indicated in Table 1, the requirements for production in the event of frequency/voltage variations must be adjusted so as not to overload the *plant*.

Voltage level descriptions	Nominal voltage $U_n$ [kV]	Minimum voltage $U_{min}$ [kV]	Maximum voltage $U_{max}$ [kV]
Low voltage (LV)	0.69	0.62	0.76
	0.40	0.34	0.44

Table 1 Nominal, minimum and maximum voltage [ref. 1 and ref. 4]

A *plant* must be able to briefly withstand voltages exceeding the maximum voltages within the required protective settings specified in section 6.2.

#### 3.2 Normal operating conditions

Within the *normal production* range, a *plant* must be able to continuously start and generate power within the design specifications, restricted only by the settings of the protective function as described in section 6.

Within the *normal production* range, the *normal operating voltage* is  $U_c + 10\%$  and  $-15\%$ , and the frequency range is 49.00 to 51.00 Hz.

Automatic connection of a *plant* can at the earliest take place three minutes after the voltage has come within the *normal operating voltage* range, and the frequency is within the 47.00 to 50.20 Hz range. The maximum permitted upward regulation of the active power is at a *droop* of  $10\% P_n/\text{min}$ . Synchronisation between the *plant* and the *public electricity supply grid* must be automatic.

The overall requirements for active power generation which a *plant* in category A1 must comply with in the event of frequency and voltage deviations are illustrated in Figure 4.

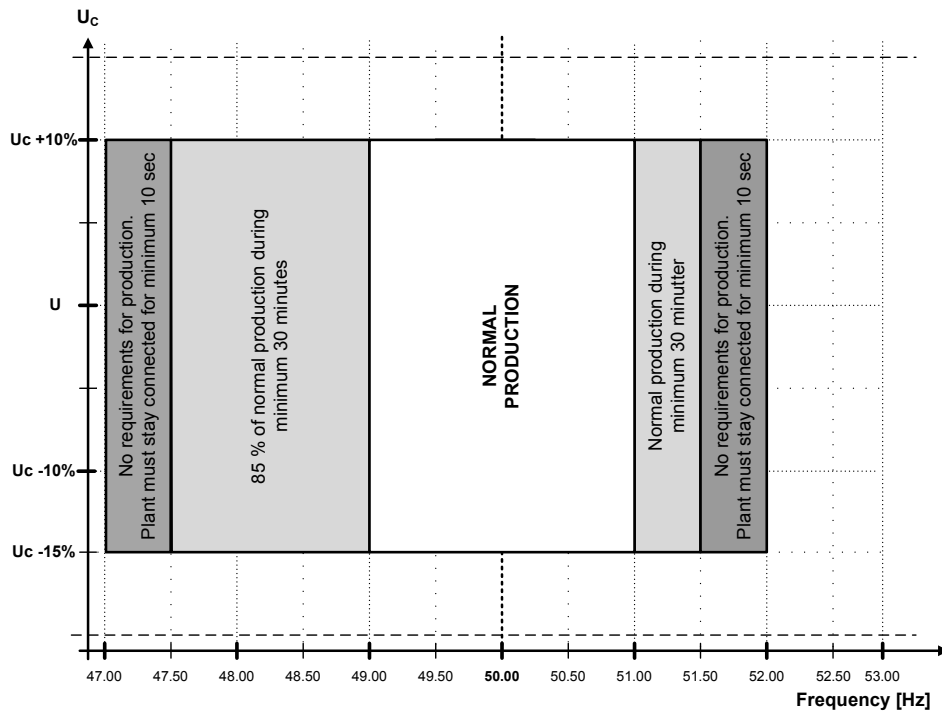

Figure 4 Active power requirements in the event of frequency and voltage fluctuations for plants in category A1.

Within the 47.00 to 52.00 Hz frequency range, the *plant* must remain connected to the *public electricity supply grid* and in accordance with the required settings for protective functions as specified in section 6.

### 3.3 Abnormal operating conditions

Under abnormal operating conditions, a *plant* in *plant category* A1 must be designed to withstand transitory (80-100 ms) phase jumps of up to 20° in the *Point of Connection* without disruption.

After a transient start-up period, the *plant* must deliver *normal production* no later than five seconds after the operating conditions in the *Point of Connection* have reverted to the *normal production* range.

## 4. Power quality

When assessing a *plant's* impact on power quality, the various power quality parameters in the *Point of Connection* must be fulfilled.

The table below lists the distortion requirements for *plant category A1*.

Requirements \ Category	A1
Voltage change (4.1)	X
DC content (4.2)	X
Asymmetry (4.3)	X
<i>Flicker</i> (4.4)	X
<i>Harmonic distortions</i> (4.5)	X
Interharmonic distortions (4.6)	-
Distortions 2-9 kHz (4.7)	-

Table 2 Overview of power quality requirements for *plant category A1*.

In addition to the requirements set in Table 2, the *plant* must meet the general EMC requirement for electrical appliances described in Directive 2004/108/EC.

Generally, the *plant owner* must ensure that the *plant* is designed, constructed and configured in such a way that the specified emission limits are observed without grid reinforcements being required.

### 4.1 Voltage changes

The inrush current must not lead to a voltage change of more than 4% in the *Point of Connection* [ref. 17]. This requirement is deemed to be met if the start-up current is less than 25A and 40A (these current values come from RA 498) [ref. 24] for single-phase or three-phase *plants*, respectively.

### 4.2 DC content

For *plants* in this *plant category*, the DC content of the supplied AC current in the *plant's Point of Connection (POC)* may not exceed 0.5% of the nominal current, see IEC/TR 61000-3-15, section 7.5 [ref. 18].

### 4.3 Asymmetry

For all *plant categories*, the asymmetry between the phases at normal operation or in the event of faults in an *electricity-generating unit* may not exceed 16A.

If the *plant* consists of multiple single-phase units, the necessary communication must be established to ensure that the above limit is not exceeded.

### 4.4 Flicker

All *plants* must meet the *flicker* emission limit value requirements in the *Point of Connection*, as described in DS/EN 61000-3-3 [ref. 17].



#### **4.5 Harmonic distortions**

All *plants* must meet the *harmonic distortion* limit value requirements in the *Point of Connection*, as described in DS/EN 61000-3-2 [ref. 16].

#### **4.6 Interharmonic distortions**

There are no interharmonic distortion emission requirements for *plant category* A1.

#### **4.7 Distortions in the 2-9 kHz frequency range**

There are no high-frequency distortion emission requirements for *plant category* A1.

## 5. Control and regulation

### 5.1 General requirements

All control functions mentioned in the following sections refer to the *Point of Connection (POC)*.

The currently activated functions and parameter settings must be agreed with the *electricity supply undertaking* within the framework laid down by the *transmission system operator*.

In order to maintain security of supply, the *transmission system operator* must be able to activate or deactivate the specified control functions by agreement with the *plant owner*.

Activation/deactivation can for instance be executed via a control panel, relay contacts or external signals as described in section 7.

The signs used in all figures follow the *generator convention*.

The required kW and kVAr services are determined relative to the number of *electricity-generating units* that make up the entire *plant*.

The minimum functionality requirements for *plants* in category A1 are listed in the table below.

Control function	Category	A1
<i>Frequency response</i> (5.2.1)		X
<i>Absolute power constraint</i> (5.2.2.1)		X
<i>Ramp rate constraint</i> (5.2.2.2)		X
<i>Q control</i> (5.3.1)*		X
<i>Power Factor control</i> (5.3.2)*		X
<i>Automatic Power Factor control</i> (5.3.3) *		X

The number in brackets in the individual rows indicates the section in which the function is described.

\*) A *plant* must not perform *Power Factor control*, *automatic Power Factor control* or *Q control* except by agreement with the *electricity supply undertaking*.

Table 3 Control functions for plants – A1.

All *plants* must be equipped with the control functions specified in Table 3.

Section 7.1 specifies how the functions in Table 3 can be activated/deactivated.

The purpose of the various control functions is to ensure overall control of the *plant's* electricity output.

## 5.2 Active power control functions

A *plant* must be equipped with active power control functions capable of controlling the active power supplied by the *plant* in the *Point of Connection*.

The current parameter settings for activated active power control functions are determined by the *electricity supply undertaking* in collaboration with the *transmission system operator* before commissioning.

It must be possible to indicate set points for active power with a resolution of at least 0.1 kW or better.

In addition to the general requirements in section 5.1, the active power control functions must comply with the requirements outlined in the following sections.

### 5.2.1 Frequency response

In the event of frequency deviations in the *public electricity supply grid*, the *plant* must contribute to grid stability by automatically reducing active power at grid frequencies above 50.00 Hz. This is referred to as *frequency response*.

The metering accuracy for the grid frequency must be  $\pm 10$  mHz or better.

It must be possible to set the *frequency response* function for the frequency points shown in Figure 5. It must be possible to set the  $f_{\min}$  and  $f_{\max}$  frequencies to any value in the 47.00-52.00 Hz range with an accuracy of 10 mHz.

It must be possible to set the frequency  $f_R$  to any value in the 50.00-52.00<sup>1</sup> Hz range with an accuracy of 10 mHz. The standard value for  $f_R$  is 50.20 Hz. The  $f_R$  setting is determined by the *transmission system operator*.

It must be possible to set the *droop* to any value in the range 2-12% of  $P_n$ , and this must be effected with an accuracy of  $\pm 10\%$  of  $P_n$ . The standard value for *droop* is 4% of  $P_n$ . In this context, *droop* is the change in active power as a function of the grid frequency. *Droop* is stated as a percentage of the *plant's* nominal output.

The *frequency response* must start no later than two seconds after a frequency change is detected and must be completed within 30 seconds.

The *electricity supply undertaking* in whose grid the *plant* is connected can coordinate initiation of the *frequency response* in relation to the trip time of island operation mode detection and thereby ensure optimal island operation mode detection functionality.

Following an incident in the *public electricity supply grid* which has resulted in downward regulation of the active power from a *plant*, the *plant* must not regulate upwards again earlier than specified in section 3.2.

<sup>1</sup> The function is deactivated if  $f_R$  is set to 52 Hz.

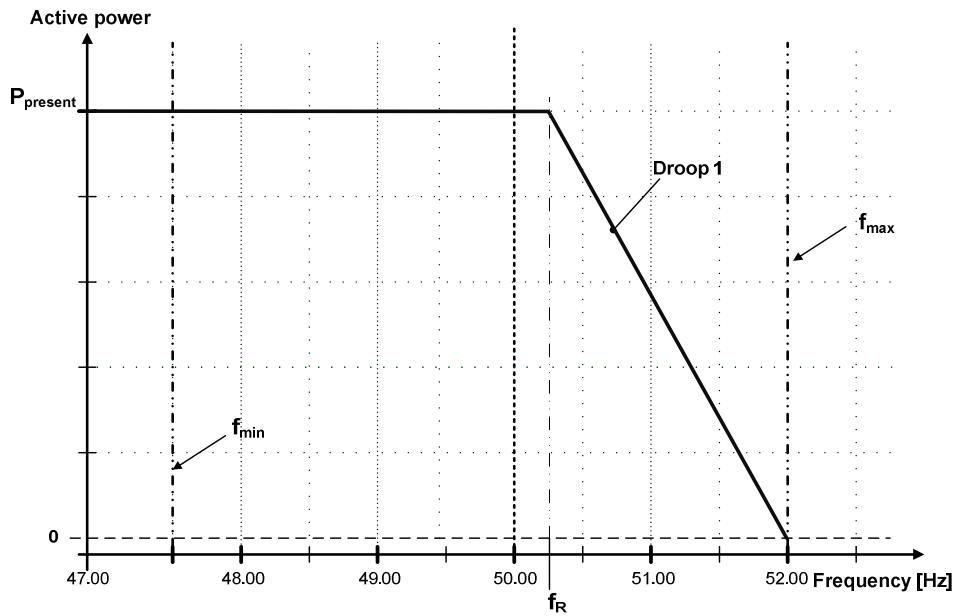

Figure 5 Frequency response for a plant.

### 5.2.2 Constraint functions

A *plant* must be equipped with constraint functions capable of controlling the active power generation from the *plant*. It must be possible to activate/deactivate these functions via a control panel, relay contacts or data communication.

The constraint functions are used to avoid instability or overloading of the *public electricity supply grid* in connection with switching in the *public electricity supply grid*, in fault situations or the like.

Figure 6 presents an overview of the active power constraint functions.

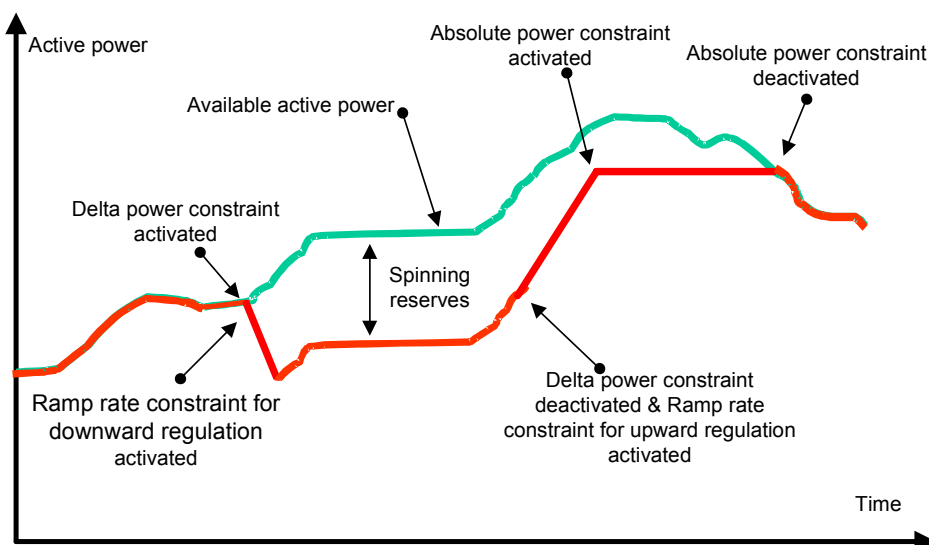

Figure 6 Drawing of constraint functions for active power.

The required constraint functions are specified in the following sections.

#### **5.2.2.1 Absolute power constraint**

*Absolute power constraint* is used to limit the active power from a *plant* to a set point-defined maximum power limit in the *Point of Connection*.

*Absolute power constraint* is mainly used to protect the *public electricity supply grid* against overload in critical situations.

The function should only be active if the *plant* is supplying ancillary services.

Control using a new parameter for the *absolute power constraint* must be commenced within two seconds and completed no later than 10 seconds after receipt of an order to change the parameter.

The accuracy of the control performed and of the set point may not deviate by more than  $\pm 5\%$  of the set point value or by  $\pm 0.5\%$  of  $P_n$ , depending on which yields the highest tolerance.

#### **5.2.2.2 Ramp rate constraint**

*Ramp rate constraint* is used to limit the maximum speed by which the active power can be changed in the event of changes in power or the set points for a *plant*.

*Ramp rate constraint* is normally used for reasons of system operation to prevent the changes in active power from adversely impacting the stability of the *public electricity supply grid*.

Control using a new parameter for the *ramp rate constraint* must be commenced within two seconds and completed no later than 10 seconds after receipt of an order to change the parameter.

The maximum standard value for the *ramp rate constraint* is 100 kW/s.

### **5.3 Reactive power control functions**

A *plant* must be equipped with reactive power control functions capable of controlling the reactive power from a *plant* in the *Point of Connection*. It must be possible to activate/deactivate these functions via a control panel, relay contacts or external signals.

The control functions for the supply of a specific reactive power (fixed Q), *Power Factor (PF) control* and automatic *Power Factor control* are mutually exclusive, which means that only one of the three functions can be activated at a time.

There are no precision and accuracy requirements for *Power Factor control* when the apparent power is less than 20% of  $P_n$ .

In addition to the general requirements in section 5.1, the reactive power control functions must comply with the requirements outlined in the following sections.

### 5.3.1 Q control

*Q control* is a control function controlling the reactive power independently of the active power in the *Point of Connection*. This control function is shown as a horizontal line in Figure 7.

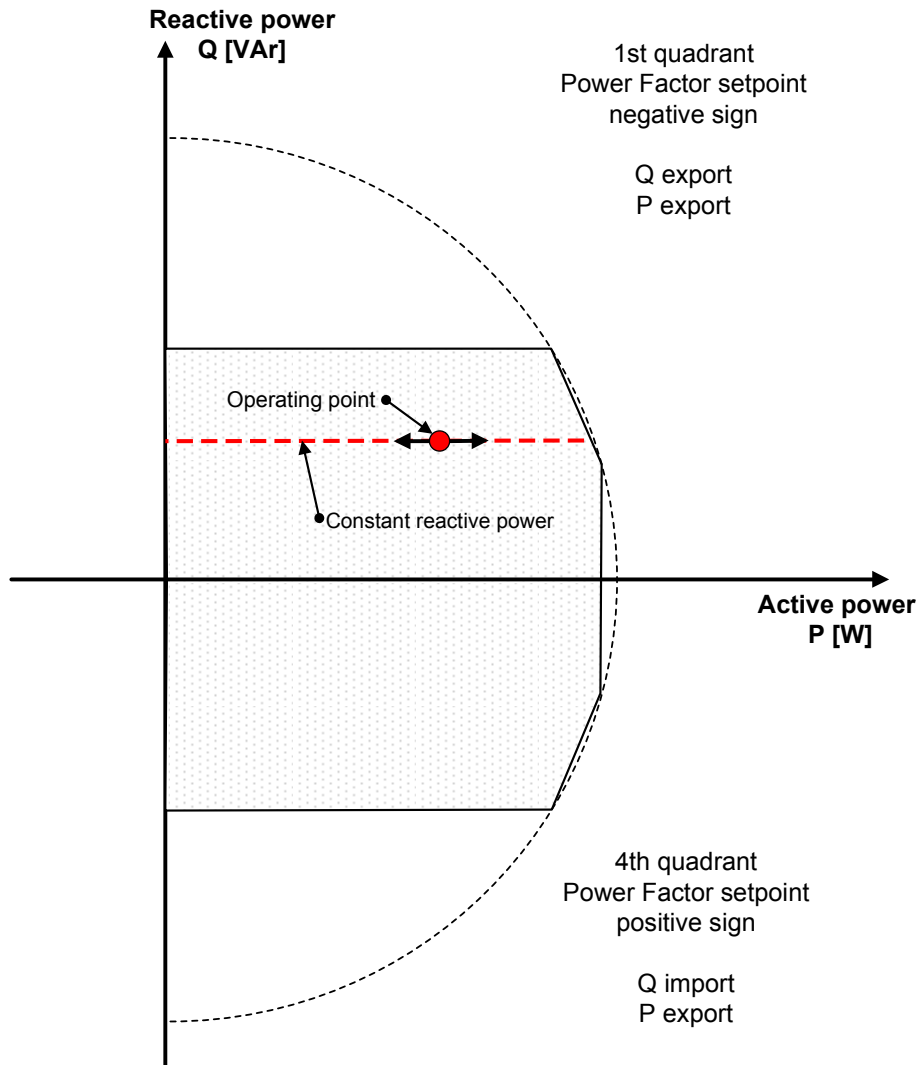

Figure 7 Reactive power control functions for a plant.

It must be possible to specify a set point for Q with a resolution of at least 0.1 kVAr or better.

The accuracy of the control performed and of the set point may not deviate by more than  $\pm 2\%$  of the set point value or by  $\pm 0.5\%$  of the *rated power*, depending on which yields the highest tolerance.

As a starting point, the function must be deactivated and must be activated only by agreement with the *electricity supply undertaking*.

### 5.3.2 Power Factor control

*Power Factor control* is a control function controlling the reactive power proportionally (determined by the *droop*) to the active power in the *Point of Connection*, which is illustrated by a line with a constant gradient in Figure 8.

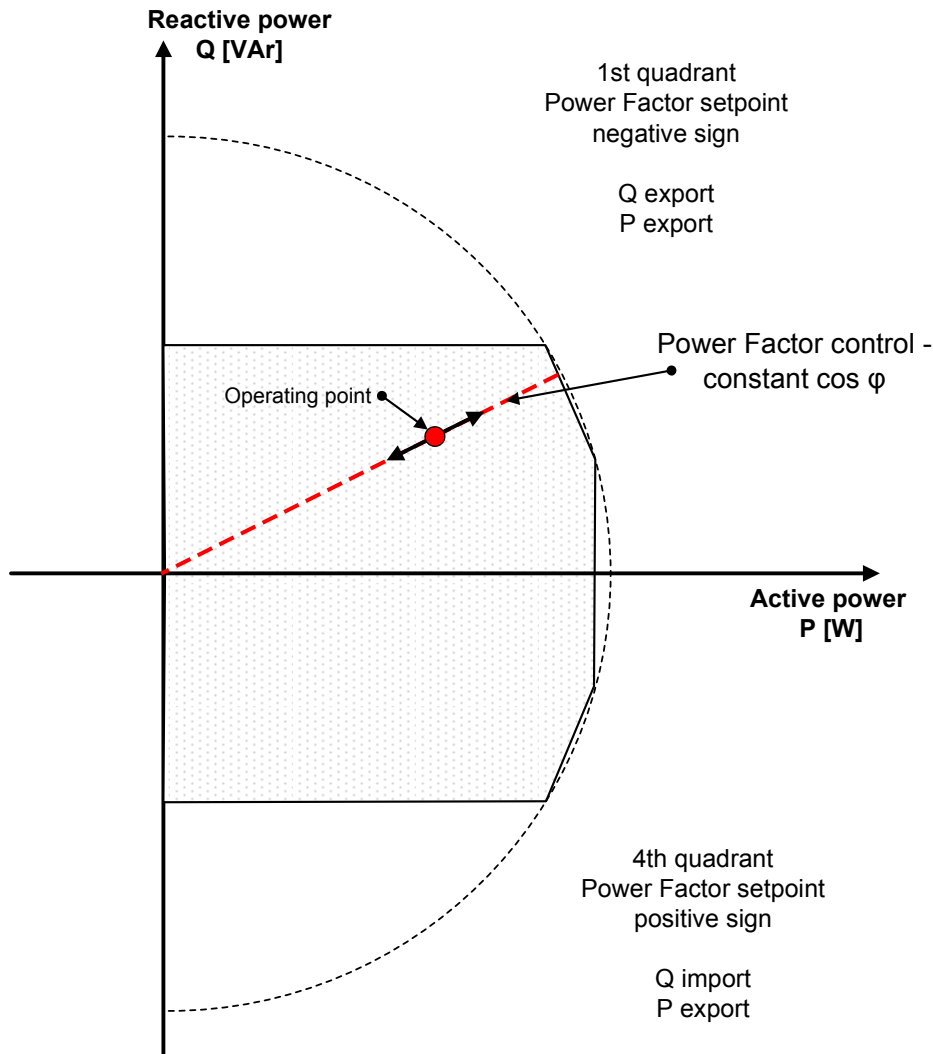

Figure 8 Power Factor (PF) control for a plant.

It must be possible to specify a set point for the *Power Factor* with a resolution of at least 0.01 or better.

The accuracy of the control performed and of the set point may not deviate by more than  $\pm 2\%$  of the set point value or by  $\pm 0.5\%$  of the *rated power*, depending on which yields the highest tolerance.

As a starting point, the function must be deactivated and must be activated only by agreement with the *electricity supply undertaking*.

### 5.3.3 Automatic Power Factor control

Automatic *Power Factor control* is a control function that automatically activates/deactivates the *Power Factor control* at defined voltage levels in the voltage reference point. The principle of the automatic *Power Factor control* is illustrated in Figure 9.

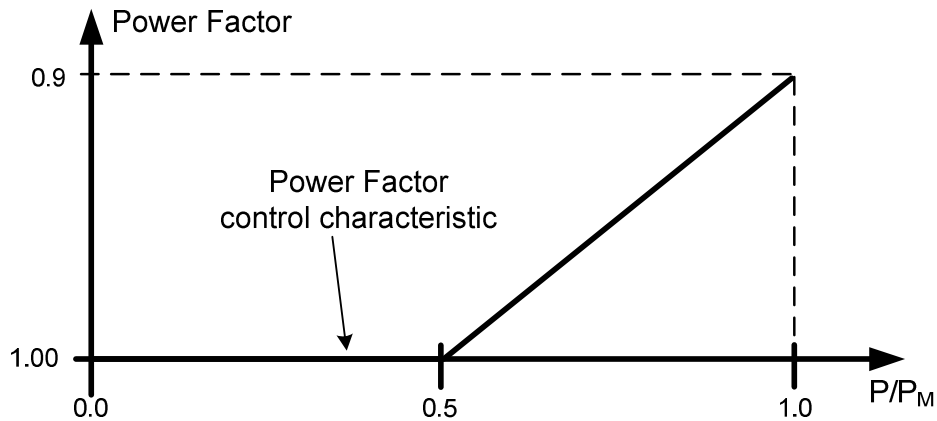

Figure 9 Automatic Power Factor control for a plant.

The default setting for the automatic *Power Factor (PF) control* is given by the following three support points with linear interpolation between them:

- 1:  $P/P_M = 0.0, PF = 1.00$
- 2:  $P/P_M = 0.5, PF = 1.00$
- 3:  $P/P_M = 1.0, PF = 0.90$

The activation level for the function is normally 105% of the *nominal voltage*, and the deactivation level is normally 100% of the *nominal voltage*. The activation/deactivation level must be configurable as a set point.

As a starting point, the function must be deactivated and must be activated only by agreement with the *electricity supply undertaking*.

### 5.4 Order of priority for control functions

The individual control functions of a *plant* must be ranked in order of priority.

A priority 1 control function takes precedence over a priority 2 control function and so forth.

The required order of priority is as follows:

1. Protective functions, see section 6
2. Constraint functions, see section 5.2.2
3. *Frequency response*, see section 5.2.1.



### 5.5 Active power control requirements

As a minimum, *plants* must be equipped with the control functions specified in Table 4.

It must be possible to indicate set points for active power with a resolution of at least 0.1 kW or better.

The table below shows the minimum functionality requirements for active power control for *plant category* A1.

<b>Control function</b>	<b>Category</b>	<b>A1</b>
<i>Frequency response</i> (5.2.1)*)		X
<i>Absolute power constraint</i> (5.2.2.1)		X
<i>Ramp rate constraint</i> (5.2.2.2)		X

The number in brackets in the individual rows indicates the section in which the function is described.

\*) By default, a *plant* must be configured with the *frequency response* function activated.

Table 4 Active power control functions – A1.

#### 5.5.1 Plant category A1

In addition to complying with the general requirements in section 5.1 and the requirements for *normal production* in section 3.2, the *plant* must be equipped with the control functions specified in Table 4.

*Plants* in this category must be prepared for receiving an external signal for production 'Stop' and an external signal 'Released for start', which allows production to start when the normal operating conditions specified in section 3.2 are met.

It must be possible to activate/deactivate these functions via a control panel, relay contacts or external signals as specified in section 7.

### 5.6 Reactive power control requirements

As a minimum, *plants* must be equipped with the control functions specified in Table 5.

The table below shows the minimum functionality requirements for reactive power control for *plant category* A1.

<b>Control function</b>	<b>Category</b>	<b>A1</b>
<i>Q control (5.3.1)*</i>		X
<i>Power Factor control (5.3.2)*</i>		X
<i>Automatic Power Factor control (5.3.3) *</i>		X

The number in brackets in the individual rows indicates the section in which the function is described.

\*) By default, a *plant* must be configured with *Q control* and with a set point of 0 VAR. Other methods of reactive power control must be agreed with the *electricity supply undertaking*.

Table 5 Reactive power control functions – A1.

### 5.6.1 Plant category A1

In addition to complying with the general requirements in section 5.1, *plants* in this category must as a minimum control their reactive power so that the *plant's* operating point lies in the *Power Factor* range from 0.90 to 1.00 at an active power output greater than 20% of the *rated power*. Unless otherwise agreed, the *plant* must follow a *Power Factor* of 1.00 by default.

It must be possible to activate/deactivate these functions via a control panel, relay contacts or external signals as specified in section 7.

The current parameter settings for reactive power control functions must be determined before commissioning by the *electricity supply undertaking* in collaboration with the *transmission system operator*. The parameter setting is selected within the *Power Factor* range specified in Figure 10.

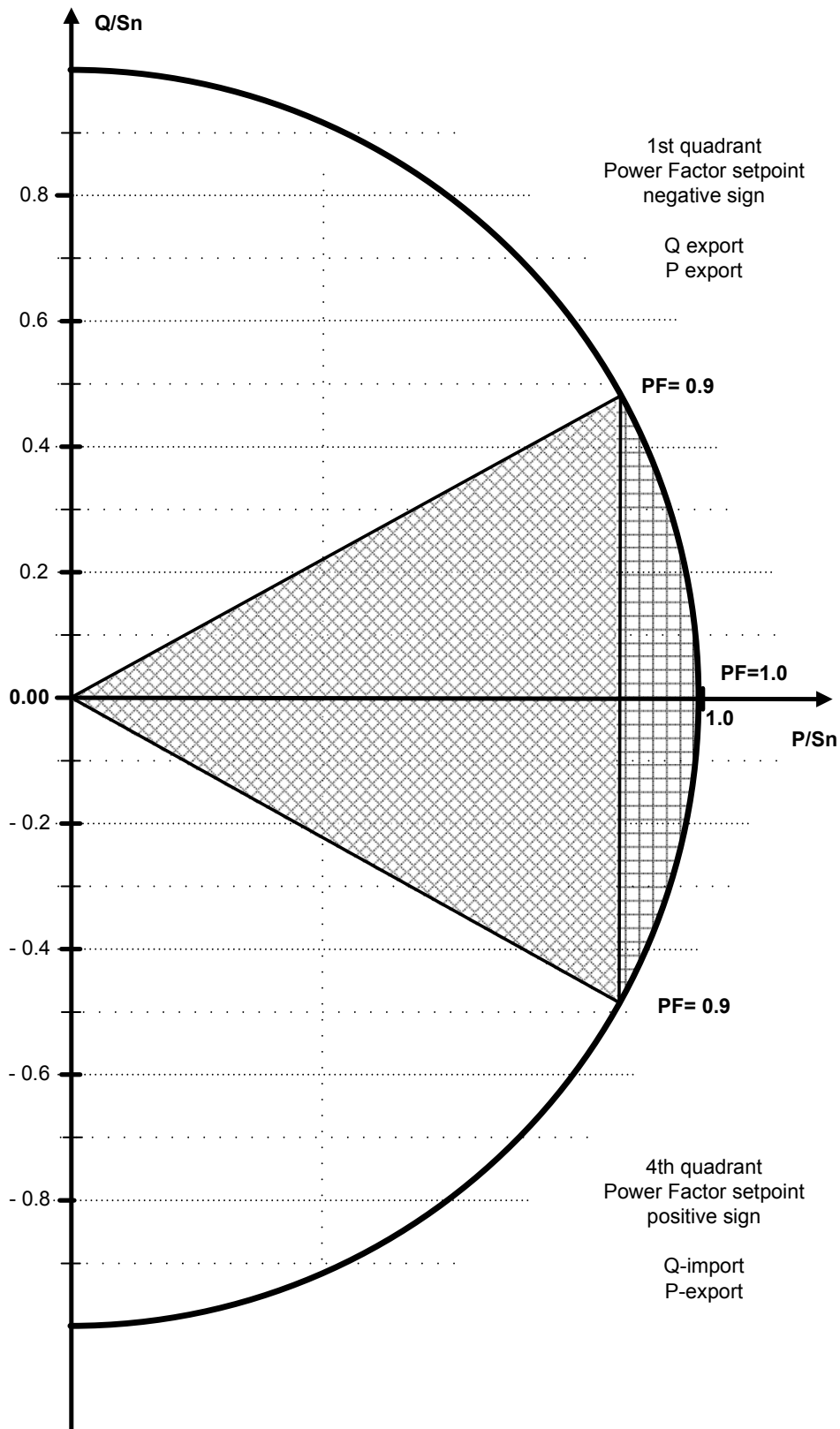

Figure 10 Requirements for the delivery of reactive power as a function of active power  $P/S_n$  for category A1 plants.

It is accepted that the ability to provide the reactive control functions in the chequered area may depend on the *plant* technology.

It must be possible to deliver the reactive power in the voltage range indicated in the figure below.

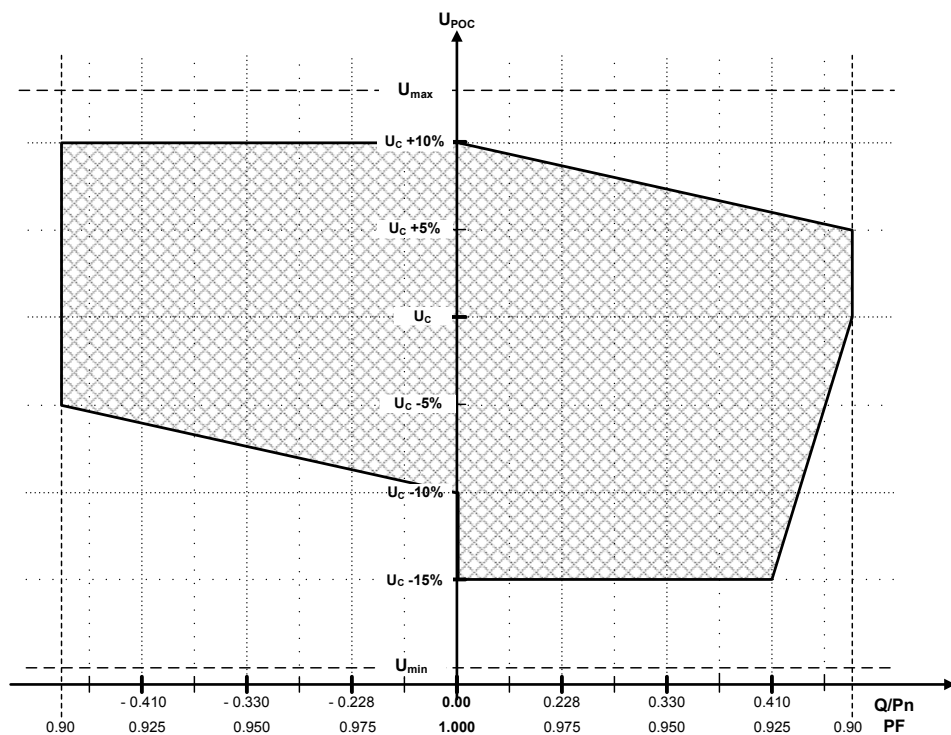

Figure 11 Requirements for the delivery of reactive power as a function of the voltage in the POC for category A1 plants [ref. 21].

## 6. Protection

### 6.1 General

The purpose of a *plant's* protective functions is to protect the *plant* and to ensure a stable *public electricity supply grid*.

The *plant owner* is responsible for ensuring that the *plant* is dimensioned and equipped with the necessary protective functions so that the *plant*:

- is protected against damage due to faults and incidents in the *public electricity supply grid*
- protects the *public electricity supply grid* to the widest possible extent against unwanted impacts from the *plant*.

The *electricity supply undertaking* or the *transmission system operator* is entitled to demand that the setting values for protective functions be changed following commissioning if it is deemed to be of importance to the operation of the *public electricity supply grid*.

However, such change must not result in the *plant* being exposed to impacts from the *public electricity supply grid* that lie outside of the design requirements specified in section 3.

Following disconnection of a *plant* due to a fault in the *public electricity supply grid*, the *plant* must not reconnect automatically earlier than specified in section 3.2.

A *plant* which has been disconnected by an external signal prior to a fault occurring in the *public electricity supply grid* must not be connected until the external signal has been eliminated, and the voltage and the frequency are once again within the normal operating conditions stated in section 3.2.

At the *plant owner's* request, the *electricity supply undertaking* must state the highest and lowest short-circuit current that can be expected in the *Point of Connection* as well as any other information about the *public electricity supply grid* as may be necessary to determine the *plant's* protective functions.

The protection configuration is shown in the figure below for a *plant* in category A1.

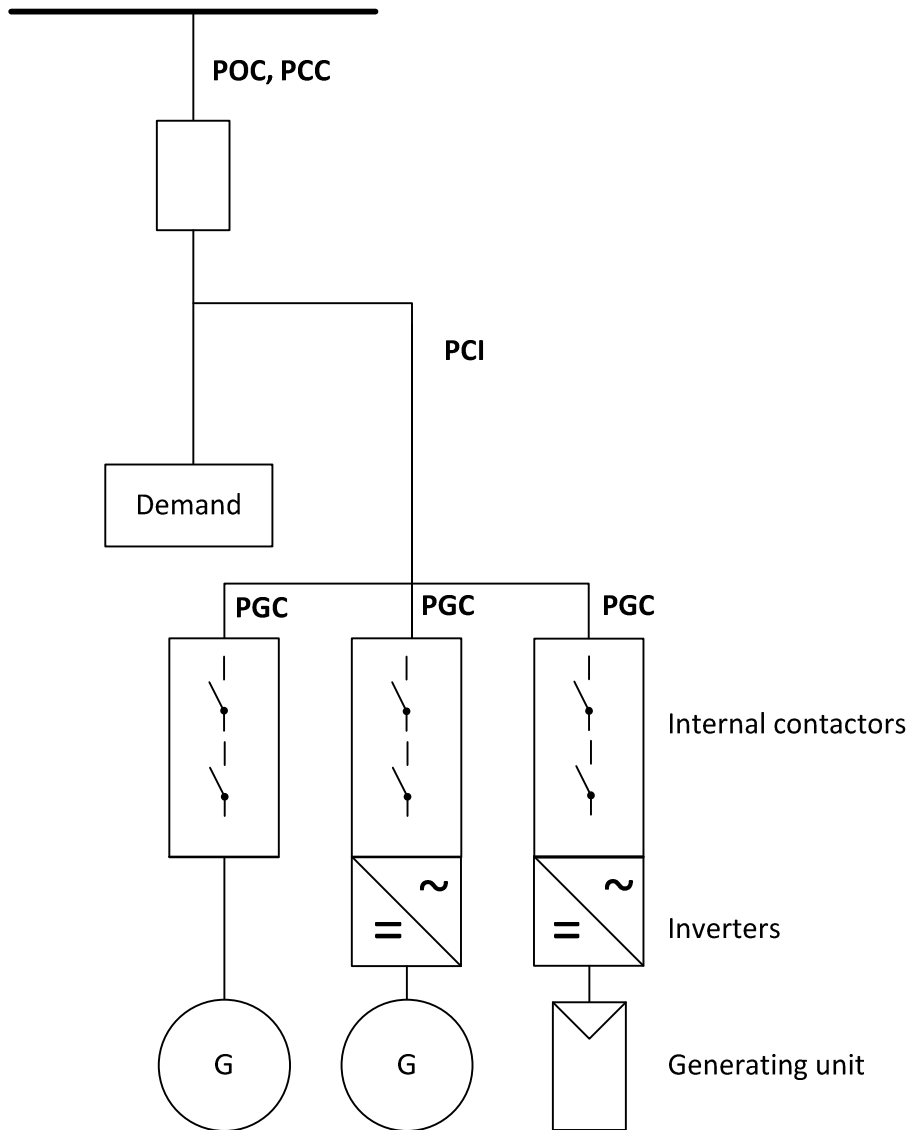

Figure 12 Overview of a plant with integrated grid protection in each unit.

### 6.2 Protective setting requirements

The *plant's* protective functions and associated settings must be as specified in the following subsections. Settings deviating from the required setting values in the event of, for example, problems with local overvoltages may only be used with the *electricity supply undertaking's* permission.

All settings are stated as RMS values.

The *plant* must be disconnected if a measuring signal deviates more from its nominal value than the setting.

The trip time stated is the measuring period during which the trip condition must constantly be fulfilled in order for the protective function to release a trip signal.

The use of vector jump relays as protection against island operation/loss of mains is not allowed.

Voltage and frequency must be measured simultaneously for the phases a *plant* is connected to in the *Point of Connection*.

The accuracy for voltage and frequency measurements must be  $\pm 1\%$  of  $U_n$  and  $\pm 0.05$  Hz, respectively.

Protective functions with associated operating settings and trip time must match the values stated in the table below.

Protective function	Symbol	Setting		Functional area		Standard setting**
Overtoltage (step 2)	$U_{>>}$	$1.15 \cdot U_n$	V	200	ms	200 ms
Overtoltage (step 1)	$U_{>}$	$1.10 \cdot U_n$	V	60	s	60 s
Undervoltage (step 1)	$U_{<}$	$0.85 \cdot U_n$	V	10...60	s	50 s
Undervoltage (step 2)***)	$U_{<<}$	$0.80 \cdot U_n$	V	100	ms	100 ms
Overfrequency	$f_{>}$	52	Hz	200	ms	200 ms
Underfrequency	$f_{<}$	47	Hz	200	ms	200 ms
Change of frequency***)	$df/dt$	$\pm 2.5$	Hz/s	50 - 100	ms	80 ms

\*\*\*) One of the specified functions must be implemented.

\*\*\*) This value is used unless agreed otherwise with the *electricity supply undertaking*.

Table 6 Protective function requirements for plants in category A1.

## 7. Data communication and exchange of signals

### 7.1 Data communication requirements

To ensure the operation of the *public electricity supply grid*, the *plant* must be prepared for signal exchange between the *plant operator* and the *electricity supply undertaking* and other players in the *plant's* communication interface (*PCOM*) in line with this regulation.

A *plant* in category A1 must, as a minimum, be prepared for receiving external signals as specified in Table 7.

Signal #	Signal description
A1.1	Stop signal
A1.2	Holding signal – 'Released for start'

Table 7 Requirements for information exchange with a category A1 plant.

The *plant* may start production when the normal operating conditions specified in section 3.2 have been met, and the 'Released for start' signal has been received.

The signals must be accessible via a terminal strip or in the *PCOM* interface via commands in accordance with the specifications in section 7.3.

It must be possible to activate/deactivate the functions specified in section 5 via a control panel, relay contacts or data communication.

### 7.2 Measurement requirements

There are no specific requirements for operational measurements for *plant category* A1 beyond the requirements for settlement metering specified in the following market regulations:

1. Regulation D1 'Settlement metering' [ref. 12]
2. Regulation D2 'Technical requirements for electricity metering' [ref. 13].

The latest versions of the applicable regulations are available on the *transmission system operator's* website [www.energinet.dk](http://www.energinet.dk).

### 7.3 Data communication

Information for a *plant* must be referred to, modelled and grouped, where possible, as specified in IEC/TR 61850-90-7 [ref. 15] and/or as described in SUNSPEC Alliance's inverter control profile. Inverters which are certified in accordance with SUNSPEC Alliance's requirements are considered to fulfil this requirement. See more details at [www.sunspec.org](http://www.sunspec.org).

If data communication is used with the *plant*, this must be available to the *electricity supply undertaking* as shown in Figure 3 in the *plant's* communication interface referred to as *PCOM*.



## 8. Verification and documentation

The *plant owner* is responsible for ensuring that the *plant* complies with this technical regulation and for documenting that the requirements are met.

The *electricity supply undertaking* and the *transmission system operator* are entitled to require at any time verification and documentation that the *plant* is in compliance with the provisions of this regulation.

The general procedure regarding the approval and issue of a final grid connection permit for a *plant* is as follows:

1. Appendix 1 must be completed and submitted electronically to the *electricity supply undertaking*.
2. The *electricity supply undertaking* reviews and approves the documentation and determines whether any information is missing.
3. Once the documentation has been approved, a final grid connection permit can be issued.

### 8.1 Documentation requirements

The requirements for the amount of documentation to be provided for *plant category A1* are stated in the table below.

Category Documentation	A1**)
Supplier statement	X
Protective functions	X
Single-line representation	X
Power quality	X

X: Documentation must be provided as described in Appendix 1.

\*\* ) May be included in the *positive list*.

Table 8 Documentation requirements for plant category A1.

#### 8.1.1 Supplier statement

By signing a supplier statement, the supplier guarantees that the specific *plant* complies with all requirements specified in TR 3.2.1. All important *plant components* must be listed in the statement.

#### 8.1.2 Protective functions

Documentation for protective functions is a list of the relay configurations applicable at the time of commissioning. These values must be stated in Appendix 1.

### 8.1.3 Single-line representation

A single-line representation is a drawing showing the main components of the *plant* and their electrical interconnections. As a minimum, the location of protective functions and metering points must be indicated in the diagram.

### 8.1.4 Power quality

Power quality is a collection of parameters characterising the quality of the power delivered. It must be indicated in Appendix 1 whether the requirements are met and where to find documentation for this.

## 8.2 Documentation requirements – plant category A1

The documentation requirements for *plant category A1* are divided between the following two sections.

### 8.2.1 Documentation for plants not included in the positive list

If the *plant* or *plant components* are not included in the *positive list*, the following documentation must be submitted to *the electricity supply undertaking* for approval no later than three months before the date of commissioning:

Appendix 1 (B1.1. ), duly completed and supplemented with the following documents:

1. CE declaration of conformity
2. Technical documentation proving that answers given in Appendix 1 (B1.1. ) are correct.

### 8.2.2 Documentation for plants included in the positive list

The supplier of a *plant* will often have used *plant components* included in the *positive list*, thus making the technical processing easier.

If the *plant* or *plant components* are included in the *positive list*, the following documentation must be submitted to *the electricity supply undertaking* for approval:

Appendix 1 (B1.2. ), duly completed.

## 8.3 Procedure for inclusion of plants and plant components in the positive list

To request that a *plant* or *plant components* be included in the *positive list*, the following documentation must be submitted to [positivlister@danskenergi.dk](mailto:positivlister@danskenergi.dk):

Appendix 1 (B1.1. ), duly completed and supplemented with the following documents:

1. CE declaration of conformity
2. Technical documentation proving that answers given in Appendix 1 (B1.1. ) are correct.

The process for inclusion in the *positive list* is explained on the Danish Energy Association's website: [www.danskenergi.dk/positivlister](http://www.danskenergi.dk/positivlister).

## Appendix 1 Documentation

Appendix 1 specifies the documentation requirements for *plant category* A1. See section B1.1. or B1.2. depending on whether *plant components* are included in the *positive list*.

The documentation, as specified in section 8, must be sent electronically to the *electricity supply undertaking*.

The technical documentation must contain configuration parameters and configuration data applicable to the *plant* at the time of commissioning.

All subsections in the appendix must be filled in for the *plant* in question.

If information changes after the time of commissioning, updated documentation must be submitted as required in section 2.2.

A template for Appendix 1 is available on the website [www.energinet.dk](http://www.energinet.dk).

**B1.1. Appendix 1 for plant category A1 not listed on the positive list**

The documentation form must be filled in with data for the *plant* valid at the time of commissioning and sent to the *electricity supply undertaking*.

**B1.1.1. Identification**

<i>Plant</i>	Description of the <i>plant</i> :
GSRN number	
<i>Plant owner</i> name and address	
<i>Plant owner</i> tel. no.	
<i>Plant owner</i> e-mail	
Type/model	
<i>Voltage (nominal)</i>	
<i>Rated power</i> (data sheet)	

**B1.1.2. Power quality**

For each power quality parameter, indicate how the result was achieved.

**B1.1.2.1. Voltage changes**

Are the voltage changes for the entire <i>plant</i> below the limit values?	Yes <input type="checkbox"/>
Where to find documentation that this requirement has been met?	No <input type="checkbox"/>

**B1.1.2.2. DC content**

<p>Does the DC content at normal operation exceed 0.5% of the nominal current?</p>	<p>Yes <input type="checkbox"/> No <input type="checkbox"/></p>
<p>Where to find documentation that this requirement has been met?</p>	

**B1.1.2.3. Asymmetry**

<p>Does the asymmetry at normal operation and during faults exceed 16 A?</p>	<p>Yes <input type="checkbox"/> No <input type="checkbox"/></p>
<p>Where to find documentation that this requirement has been met?</p>	
<p>If the <i>plant</i> is made up of single-phase <i>electricity-generating units</i>, have you taken measures to ensure that the above limit is not exceeded?</p>	<p>Yes <input type="checkbox"/> No <input type="checkbox"/></p>
<p>Where to find documentation that this requirement has been met?</p>	

**B1.1.2.4. Flicker**

<p>Is the <i>flicker</i> contribution for the entire <i>plant</i> below the limit value?</p>	<p>Yes <input type="checkbox"/> No <input type="checkbox"/></p>
<p>Where to find documentation that this requirement has been met?</p>	

**B1.1.2.5. Harmonic distortions**

<p>Are all <i>harmonic distortions</i> for the entire <i>plant</i> below the limit values?</p>	<p>Yes <input type="checkbox"/> No <input type="checkbox"/></p>
<p>Where to find documentation that this requirement has been met?</p>	

**B1.1.3. Connection and synchronisation**

<p>Can the <i>plant</i> be started and generate power continuously within the <i>normal production</i> range, limited only by the protective settings?</p> <p>Where to find documentation that this requirement has been met?</p>	<p>Yes <input type="checkbox"/></p> <p>No <input type="checkbox"/></p>
<p>Do connection and synchronisation occur three minutes, at the earliest, after voltage and frequency have come within the <i>normal production</i> range?</p> <p>Where to find documentation that this requirement has been met?</p>	<p>Yes <input type="checkbox"/></p> <p>No <input type="checkbox"/></p>

**B1.1.4. Active power control at overfrequency**

<p>Is the <i>plant</i> equipped with a <i>frequency response</i> function?</p> <p>Is the function activated?</p> <p>Where to find documentation that these requirements have been met?</p>	<p>Yes <input type="checkbox"/></p> <p>No <input type="checkbox"/></p> <p>Yes <input type="checkbox"/></p> <p>No <input type="checkbox"/></p>
--	---

**B1.1.5. Absolute power constraint function**

<p>Is the <i>plant</i> equipped with an <i>absolute power constraint</i> function?</p> <p>Is the function activated?</p> <p>Where to find documentation that these requirements have been met?</p>	<p>Yes <input type="checkbox"/></p> <p>No <input type="checkbox"/></p> <p>Yes <input type="checkbox"/></p> <p>No <input type="checkbox"/></p>
--	---

**B1.1.6. Ramp rate constraint function**

<p>Is the <i>plant</i> equipped with a <i>ramp rate constraint</i> function?</p>	<p>Yes <input type="checkbox"/> No <input type="checkbox"/></p>
<p>Is the function activated?</p>	<p>Yes <input type="checkbox"/> No <input type="checkbox"/></p>
<p>Where to find documentation that these requirements have been met?</p>	

**B1.1.7. Reactive power control**

<p>Reactive power can be controlled by means of</p>	<p><i>Q control</i> <input type="checkbox"/> <i>Power Factor control</i> <input type="checkbox"/> <i>Automatic Power Factor control</i> <input type="checkbox"/></p>
---	--

**B1.1.8. Q control**

<p>Is the control function activated with a set point of _____ VAR? (Value may not differ from 0 VAR unless agreed with the <i>electricity supply undertaking</i>).</p>	<p>Yes <input type="checkbox"/> No <input type="checkbox"/></p>
<p>Where to find documentation that this requirement has been met?</p>	

**B1.1.9. Power Factor control**

<p>Is the control function deactivated?</p>	<p>Yes <input type="checkbox"/> No <input type="checkbox"/></p>
<p>Where to find documentation that this requirement has been met?</p>	

**B1.1.10. Automatic Power Factor control**

<p>Is the control function deactivated?</p>	<p>Yes <input type="checkbox"/> No <input type="checkbox"/></p>
<p>Where to find documentation that this requirement has been met?</p>	

**B1.1.11. Protection against electricity system faults**

**B1.1.11.1. Relay settings**

In the table below, indicate the values at the time of commissioning.

Protective function	Symbol	Setting		Trip time	
Overvoltage (step 2)	$U_{>>}$		V		ms
Overvoltage (step 1)	$U_{>}$		V		s
Undervoltage (step 1)	$U_{<}$		V		s
Undervoltage (step 2)	$U_{<<}$		V		ms
Overfrequency	$f_{>}$		Hz		ms
Underfrequency	$f_{<}$		Hz		ms
Change of frequency	$df/dt$		Hz/s		ms

**B1.1.11.2. Central protection**

<p>Has a central protection unit been installed?</p> <p>Where is it located?</p> <p>Where to find documentation that these requirements have been met?</p>	<p>Yes <input type="checkbox"/></p> <p>No <input type="checkbox"/></p> <p><i>PCI</i> <input type="checkbox"/></p> <p><i>POC</i> <input type="checkbox"/></p>
<p>Has consumption been connected after the protection unit?</p> <p>Where to find documentation that this requirement has been met?</p>	<p>Yes <input type="checkbox"/></p> <p>No <input type="checkbox"/></p>

**B1.1.12. Signature**

Date of commissioning	
Company	
Person responsible for commissioning	
Signature	



**B1.2. Appendix 1 for plant category A1 listed on the positive list**

The documentation form must be filled in with data for the *plant* at the time of commissioning and sent to the *electricity supply undertaking*.

**B1.2.1. Identification**

<i>Plant</i>	Description of the <i>plant</i> :
GSRN number	
<i>Plant owner</i> name and address	
<i>Plant owner</i> tel. no.	
<i>Plant owner</i> e-mail	
Type/model	
<i>Voltage (nominal)</i>	
<i>Rated power (data sheet)</i>	

**B1.2.2. Active power control at overfrequency**

Is the <i>plant</i> equipped with a <i>frequency response</i> function?	Yes <input type="checkbox"/> No <input type="checkbox"/>
Is the function activated?	Yes <input type="checkbox"/> No <input type="checkbox"/>

**B1.2.3. Absolute power constraint function**

Is the <i>plant</i> equipped with an <i>absolute power constraint</i> function?	Yes <input type="checkbox"/> No <input type="checkbox"/>
Is the function activated?	Yes <input type="checkbox"/> No <input type="checkbox"/>

**B1.2.4. Reactive power control**

Reactive power can be controlled by means of	<i>Q control</i> <input type="checkbox"/> <i>Power Factor control</i> <input type="checkbox"/> <i>Automatic Power Factor control</i> <input type="checkbox"/>
--	---

**B1.2.5. Q control**

Is the control function activated with a set point of _____ VAR? (Value may not differ from 0 VAR unless agreed with the <i>electricity supply undertaking</i> ).	Yes <input type="checkbox"/> No <input type="checkbox"/>
--	---

**B1.2.6. Power Factor control**

Is the control function deactivated?	Yes <input type="checkbox"/> No <input type="checkbox"/>
--------------------------------------	---

**B1.2.7. Automatic Power Factor control**

Is the control function deactivated?	Yes <input type="checkbox"/> No <input type="checkbox"/>
--------------------------------------	---

**B1.2.8. Protection against electricity system faults**

**B1.2.8.1. Relay settings**

In the table below, indicate the values at the time of commissioning.

Protective function	Symbol	Setting		Trip time	
Overvoltage (step 2)	$U_{>>}$		V		ms
Overvoltage (step 1)	$U_{>}$		V		s
Undervoltage (step 1)	$U_{<}$		V		s
Undervoltage (step 2)	$U_{<<}$		V		ms
Overfrequency	$f_{>}$		Hz		ms
Underfrequency	$f_{<}$		Hz		ms
Change of frequency	$df/dt$		Hz/s		ms

**B1.2.8.2. Central protection**

<p>Has a central protection unit been installed?</p> <p>Where is it located?</p>	<p>Yes <input type="checkbox"/></p> <p>No <input type="checkbox"/></p> <p><i>PCI</i> <input type="checkbox"/></p> <p><i>POC</i> <input type="checkbox"/></p>
<p>Has consumption been connected after the protection unit?</p>	<p>Yes <input type="checkbox"/></p> <p>No <input type="checkbox"/></p>

**B1.2.9. Signature**

<p>Date of commissioning</p>	
<p>Company</p>	
<p>Person responsible for commissioning</p>	
<p>Signature</p>	