



# Technical regulation 3.2.2 for PV power plants above 11 kW

4	Published UK edition	30.06.2016	30.06.2016	30.06.2016	14.07.2016	DATE
		KDJ	FBN	BJA	APJ	NAME
REV.	DESCRIPTION	PREPARED	CHECKED	REVIEWED	APPROVED	
		<b>14/17997-39</b>				

## Revision view

Section no.	Text	Revision	Date
All sections	This regulation has been amended based on consultation responses received. Editorial errors were corrected. Corrections were made to ensure consistency with the wording of other technical regulations.	4	14.07.2016
All sections Figures 15, 17, 19  Sections 4.4.3.1, 4.4.4.1, 4.5.2.1, 4.5.3.1, 4.6.2.1, 4.7.2.1, 4.7.3.1  Section 8  Appendix 1	Public consultation document: Editorial errors were corrected in several sections of the document. Errors in the text on the Y-axes in figures 15, 17 and 19 were corrected.  Section 4.4.3.1 – Requirements added for category A2 Section 4.4.4.1 – Requirements added for category A2 Section 4.5.2.1 – Requirements added for category A2 Section 4.5.3.1 – Requirements added for category A2 Section 4.6.2.1 – Requirements added for category A2 Section 4.7.2.1 – Requirements added for category A2 Section 4.7.3.1 – Requirements added for category A2  Section 8 adjusted to reflect the change in responsibilities concerning the <i>positive lists</i> .  Appendix 1 corrected, dividing documentation requirements for <i>plant category A2</i> into two groups – one with <i>plant components</i> on the <i>positive list</i> , and one with <i>plant components</i> not on the <i>positive list</i> .	3	06.05.2016
Section 1.1 Section 1.2 Section 2.5 Section 2.6  Section 5.2.1 Figures 15, 17 and 19 Table 11 Appendix 1	Missing abbreviations were added. Editorial errors in the definitions were corrected. Corrections were made to ensure consistency. Address of the Danish Energy Regulatory Authority was corrected. Text was amended in accordance with other technical regulations. Designation on the X-axis was corrected.  Amended to ensure consistency between Table 10 and Table 11. Text was amended in accordance with the specifications of the regulation.	2	24.07.2015
Sections 2.2, 2.6, 2.8, Appendix 1	Text was amended according to comments received from the Danish Energy Regulatory Authority. Appendix 1 has been prepared so that the layout and text are consistent with the separate Appendix 1 document.	1	10.03.2015
	This regulation has been registered with the Danish Energy Regulatory Authority.	0	27.11.2014

## Table of contents

Revision view .....	2
Table of contents.....	3
List of figures and tables .....	4
Reading instructions .....	6
1. Terminology, abbreviations and definitions.....	7
2. Objective, scope of application and regulatory provisions .....	20
3. Tolerance of frequency and voltage deviations .....	26
4. Power quality.....	32
5. Control and regulation .....	42
6. Protection .....	63
7. Exchange of signals and data communication .....	70
8. Verification and documentation .....	77
9. Electrical simulation model .....	81
Appendix 1 Documentation .....	84

## List of figures and tables

### List of figures:

Figure 1	Definition of sign for active power, reactive power, Power Factor set points and reference for Power Factor angle. ....	13
Figure 2	Example of installation connection of a PV power plant. ....	16
Figure 3	Example of connection of a PV power plant. ....	17
Figure 4	Requirements for active power production in the event of frequency and voltage fluctuations.....	27
Figure 5	Voltage dip tolerance requirements for category C and D PV power plants.....	29
Figure 6	Requirements for the delivery of additional reactive current $I_Q$ during voltage dips for category C and D PV power plants.....	30
Figure 7	Drawing of a plant controller. ....	44
Figure 8	Frequency response for a PV power plant.....	45
Figure 9	Frequency control curve for a PV power plant. ....	47
Figure 10	Drawing of constraint functions for active power. ....	48
Figure 11	Reactive power control functions for a PV power plant. ....	49
Figure 12	Power Factor control (PF) for a PV power plant. ....	50
Figure 13	Voltage control for a PV power plant.....	52
Figure 14	Automatic Power Factor control (PF) for a PV power plant. ....	53
Figure 15	Requirements for the delivery of reactive power as a function of $P/S_n$ for category B PV power plants. ....	57
Figure 16	Requirements for the delivery of reactive power as a function of the voltage in the POC for category B PV power plants. ....	58
Figure 17	Requirements for the delivery of reactive power as a function of $P/S_n$ for category C PV power plants. ....	59
Figure 18	Requirements for the delivery of reactive power as a function of voltage in the POC for category C PV power plants. ....	60
Figure 19	Requirements for the delivery of reactive power as a function of $P/S_n$ for category D PV power plants. ....	61
Figure 20	Requirements for the delivery of reactive power as a function of the voltage in the POC for category D PV power plants.....	62
Figure 21	Overview of plants with integrated grid protection in the inverters. ....	64
Figure 22	Overview of plants with central grid protection. ....	65
Figure 23	Overview of plants with inverters connected to local grid protection. ....	66

**List of tables:**

Table 1	Definition of voltage levels used in this regulation. ....	26
Table 2	Types and duration of faults in the public electricity supply grid. ...	31
Table 3	Overview of power quality requirements for plant categories. ....	32
Table 4	Limit values for long-term flicker $P_{lt}$ . ....	34
Table 5	Limit values for short-term flicker $P_{st}$ and long-term flicker $P_{lt}$ . ....	35
Table 6	Limit values for harmonic current $I_h/I_n$ (% of $I_n$ ) – A2. ....	36
Table 7	Limit values for total harmonic current distortion (% of $I_n$ ) – A2. ...	36
Table 8	Limit values for harmonic current $I_h/I_n$ (% of $I_n$ ) – B. ....	37
Table 9	Limit values for total harmonic current distortion (% of $I_n$ ) – B. ...	37
Table 10	Limit values for total harmonic voltage distortion THD <sub>U</sub> (% of $U_n$ ). ...	37
Table 11	Values for the exponent $\alpha$ . ....	38
Table 12	Limit values for interharmonic distortion emissions – B. ....	40
Table 13	Overview of control functions required for PV power plants. ....	43
Table 14	Active power control functions. ....	54
Table 15	Reactive power control functions. ....	55
Table 16	Requirements for category A2 PV power plants. ....	67
Table 17	Requirements for category B PV power plants. ....	68
Table 18	Requirements for category C PV power plants. ....	68
Table 19	Requirements for category D PV power plants. ....	69
Table 20	Requirements for information exchange with a category A2 PV power plant. ....	72
Table 21	Requirements for control function parameters – A2. ....	72
Table 22	Requirements for information exchange with a category B PV power plant. ....	73
Table 23	Requirements for control function parameters for category B PV power plants. ....	73
Table 24	Requirements for information exchange with a category C PV power plant. ....	74
Table 25	Requirements for information exchange with a category D PV power plant. ....	75
Table 26	Documentation requirements for PV power plants. ....	77

## Reading instructions

This regulation covers the technical and functional minimum requirements which *PV power plants* with a *rated power* above 11 kW must comply with if they are to be connected to the Danish grid.

The regulation is structured so that section 1 contains the terminology and definitions used; section 2 describes the regulatory provisions and relevant references, while sections 3 through 7 cover the technical and functional requirements. Section 8 contains the requirements for documentation of the different *plant categories*, and section 9 covers the requirements for the electrical simulation model for the different *wind power plant categories*.

The technical requirements of the regulation are divided into four *plant categories* as described in sections 1.2.21 and 2.2.

The regulation makes extensive use of terminology and definitions. The terms, abbreviations and definitions used are described in section 1. Throughout the regulation, terminology and definitions are written in *italics*.

The regulation is also published in English. In case of doubt, the Danish version applies.

The *transmission system operator (TSO)* publishes the regulation which is available on the website [www.energinet.dk](http://www.energinet.dk).

# 1. Terminology, abbreviations and definitions

## 1.1 Abbreviations

This section contains the abbreviations used in the document.

### 1.1.1 $\Psi_k$

$\Psi_k$  is used as an abbreviation for the short circuit angle in the *Point of Connection*. Flicker values are calculated using the  $\psi_k$  parameter.

### 1.1.2 $c_f$

The flicker coefficient must be indicated by  $c_f$ .

### 1.1.3 $d(\%)$

$d(\%)$  denotes *rapid voltage changes* in % of  $U_n$ . See section 1.2.40 for more detail.

### 1.1.4 $df/dt$

$df/dt$  denotes the frequency change as a function of time. See section 1.2.6 for more detail.

### 1.1.5 $f_<$

$f_<$  denotes the operational setting for underfrequency in the relay protection. See section 6 for more detail.

### 1.1.6 $f_>$

$f_>$  denotes the operational setting for overfrequency in the relay protection. See section 6 for more detail.

### 1.1.7 $f_R$

$f_R$  denotes the frequency at which a *PV power plant* is to begin downward regulation with the agreed *droop*. See section 5.2.1 for more detail.

### 1.1.8 $f_x$

$f_x$ , where x may be 1 to 7 or minimum and maximum, are points used for *frequency control*. See section 5.2.2 for more detail.

### 1.1.9 $G_{It}$

$G_{It}$  denotes the planning value of the flicker emission from a *plant*.

### 1.1.10 $I_h$

$I_h$  denotes the sum of the individual harmonic currents.

### 1.1.11 $I_n$

The *rated current*  $I_n$  is the maximum continuous current that a *plant* or an *electricity-generating unit* is designed to deliver. See section 1.2.41 for more detail.

### 1.1.12 $I_Q$

The reactive current delivered or absorbed by a *plant* is referred to as  $I_Q$ .

**1.1.13  $k_u$** 

The voltage change factor is denoted by  $k_u$ . The voltage change factor is calculated as a function of  $\psi_k$ .

**1.1.14  $P_{\text{current}}$** 

$P_{\text{current}}$  denotes the current level of active power.

**1.1.15  $P_d$** 

$P_d$  denotes the maximum active power that an *electricity-generating unit* can generate at a  $PF=0.9$ .

**1.1.16  $P_{\text{delta}}$** 

$P_{\text{delta}}$  denotes a rolling reserve. See section 5.2.2 for more detail.

**1.1.17  $P_{\text{lt}}$** 

$P_{\text{lt}}$  denotes the long-term *flicker* emission from a *plant*.  $P_{\text{lt}}$  stands for 'long-term' and is assessed over a period of two hours. See IEC 61000-3-7 [ref. 20] for more detail.

**1.1.18  $P_M$** 

$P_M$  indicates the active power which can be generated under the given circumstances.

**1.1.19  $P_n$** 

$P_n$  denotes the *rated power* of a *plant*. See section 1.2.42 for more detail.

**1.1.20  $P_{\text{st}}$** 

$P_{\text{st}}$  denotes the short-term *flicker* emission from a *plant*.  $P_{\text{st}}$  stands for 'short term' and is assessed over a period of 10 minutes. See IEC 61000-3-7 [ref. 20] for more detail.

**1.1.21  $P_{\text{available}}$** 

$P_{\text{available}}$  denotes the available active power.

**1.1.22 PCC**

*Point of Common Coupling (PCC)*. See section 1.2.27 for more detail.

**1.1.23 PCI**

*Point of Connection in Installation (PCI)*. *PCI* is the point in the installation where the *plant* is connected and where consumption is connected. See section 1.2.30 for more detail.

**1.1.24 PCOM**

*Point of Communication (PCOM)*. See section 1.2.28 for more detail.

**1.1.25 PF**

*Power Factor (PF)*. See section 1.2.33 for more detail.

**1.1.26 PGC**

*Point of Generator Connection*. *PGC* is the point defined by the supplier of a *PV power plant* as the *plant* terminals. See section 1.2.31 for more detail.



**1.1.27 POC**

*Point of Connection*. See section 1.2.29 for more detail.

**1.1.28 PWHD**

*PWHD* is the abbreviation used for *Partial Weighted Harmonic Distortion*. See section 1.2.19 for more detail.

**1.1.29  $Q_{\max}$** 

$Q_{\max}$  denotes the maximum level of reactive power at a *Power Factor* of 0.95 lagging that a *plant* can deliver.

**1.1.30  $Q_{\min}$** 

$Q_{\min}$  denotes the minimum level of reactive power at a *Power Factor* of 0.95 leading that a *plant* can absorb.

**1.1.31  $S_i$** 

$S_i$  denotes the apparent power of an *electricity-generating unit* no.  $i$ .

**1.1.32  $S_k$** 

$S_k$  denotes the *short circuit power*. See section 1.2.44 for more detail.

**1.1.33  $S_{\text{last}}$** 

$S_{\text{last}}$  denotes the apparent power for the total radial load.

**1.1.34  $S_n$** 

$S_n$  denotes the nominal apparent power for a *plant*.

**1.1.35  $S_{\text{out}}$** 

$S_{\text{out}}$  denotes the apparent power for the total radial output.

**1.1.36 SCR**

*SCR* is the abbreviation used for the *short circuit ratio* of the *Point of Connection*.

**1.1.37 THD**

*THD* is the abbreviation used for *Total Harmonic Distortion*. See section 1.2.46 for more detail.

**1.1.38  $U_c$** 

$U_c$  denotes the *normal operating voltage*. See section 1.2.17 for more detail.

**1.1.39  $U_h$** 

$U_h$  denotes the sum of the harmonic voltages.

**1.1.40  $U_{\max}$** 

$U_{\max}$  denotes the maximum *nominal voltage*  $U_n$  that an *electricity-generating unit* may be exposed to.

**1.1.41  $U_{\min}$** 

$U_{\min}$  denotes the minimum *nominal voltage*  $U_n$  that an *electricity-generating unit* may be exposed to.

**1.1.42  $U_n$** 

$U_n$  denotes the *nominal voltage*. This voltage is measured phase to phase. See section 1.2.16 for more detail.

**1.1.43  $U_{POC}$** 

$U_{POC}$  denotes the *normal operating voltage* in the *POC*. See section 1.2.29 for more detail.

**1.1.44 UTC**

UTC is an abbreviation of Coordinated Universal Time (Universal Time, Coordinated).

**1.1.45  $Z_{net,h}$** 

$Z_{net,h}$  denotes the grid impedance at frequency  $h$ .

## 1.2 Definitions

This section contains the definitions used in the document. Several of the definitions are derived from IEC 60050-415:1999 [ref. 16], but have been modified as needed in this regulation.

### 1.2.1 Absolute power constraint

Adjustment of active power to a maximum level is indicated by a set point. The +/- tolerance of the set point adjustment is referred to as the *absolute power constraint*. See section 5.2.3.1 for more detail.

### 1.2.2 Automatic Power Factor control

*Automatic Power Factor control* is the control of the reactive power with a variable *PF* depending on the active power generated.

### 1.2.3 Balance-responsible party for production

A *balance-responsible party for production* is financially accountable to the *transmission system operator*.

The *balance-responsible party for production* holds the balance responsibility for a given *plant vis-à-vis* the *transmission system operator*.

### 1.2.4 COMTRADE

*COMTRADE* (Common Format for Transient Data) [ref. 34] is a standardised file format specified in IEEE standard C37.111-2013. The format is designed for the exchange of information on transient phenomena occurring in connection with faults and switching in electricity systems.

The standard includes a description of the required file types and the sources of transient data such as protective relays, fault recorders and simulation programs. The standard also defines sample rates, filters and the conversion of transient data to be exchanged.

### 1.2.5 Delta power constraint

A *delta power constraint* is a function which controls the active power with a set point-defined deviation (delta) between the potential and actual power. See section 5.2.3.2 for more detail.

### 1.2.6 $df/dt$

$df/dt$  denotes the frequency change as a function of time.

The frequency change,  $df/dt$ , is calculated according to the principle below or an equivalent principle. The frequency measurement used to calculate the frequency change is based on an 80-100 ms measuring period for which the mean value is calculated. Frequency measurements must be carried out continuously, so that a new value is calculated for every 20 ms.  $df/dt$  must be calculated as the difference between the frequency calculation just carried out and the frequency calculation carried out 80-100 ms ago.

The  $df/dt$  function is used in decentralised generation facilities to detect situations of island operation where island operation occurs without prior voltage dip.

### 1.2.7 Droop

*Droop* is the trajectory of a curve which a control function must follow.

### 1.2.8 Electricity supply undertaking

The *electricity supply undertaking* is the enterprise to whose grid a *plant* is electrically connected. Responsibilities in the *public electricity supply grid* are distributed onto several grid companies and one transmission enterprise.

The grid company is the company licensed to operate the *public electricity supply grid* of **up to** 100 kV.

The transmission enterprise is the enterprise licensed to operate the *public electricity supply grid* **above** 100 kV.

### 1.2.9 Electricity-generating unit

An *electricity-generating unit* is a unit which generates electricity, and which is directly or indirectly connected to the *public electricity supply grid*. In a PV context, the term PV panel is often used for an *electricity-generating unit*.

### 1.2.10 Flicker

*Flicker* is a visual perception of light flickering caused by *voltage fluctuations*. *Flicker* occurs if the luminance or the spectral distribution of light fluctuates with time. At a certain intensity, *flicker* becomes an irritant to the eye.

*Flicker* is measured as described in IEC 61000-4-15 [ref. 9].

### 1.2.11 Frequency control

The *frequency control* controls active power with the aim of stabilising the grid frequency. The function is referred to as *frequency control*. See section 5.2.2 for more detail.

### 1.2.12 Frequency response

*Frequency response* is the automatic downward regulation of active power as a function of grid frequencies above a certain frequency  $f_R$  with a view to stabilising the grid frequency. See section 5.2.1 for more detail.

### 1.2.13 Generator convention

The sign for active/reactive power indicates the power flow seen from the generator. The consumption/import of active/reactive power is indicated by means of a negative sign, while the generation/export of active/reactive power is indicated by means of a positive sign.

The sign of the *Power Factor* set point is used to determine whether control should take place in the first or the fourth quadrant. For *Power Factor* set points, two pieces of information are thus combined into a single signal: a set point value and the choice of control quadrant.

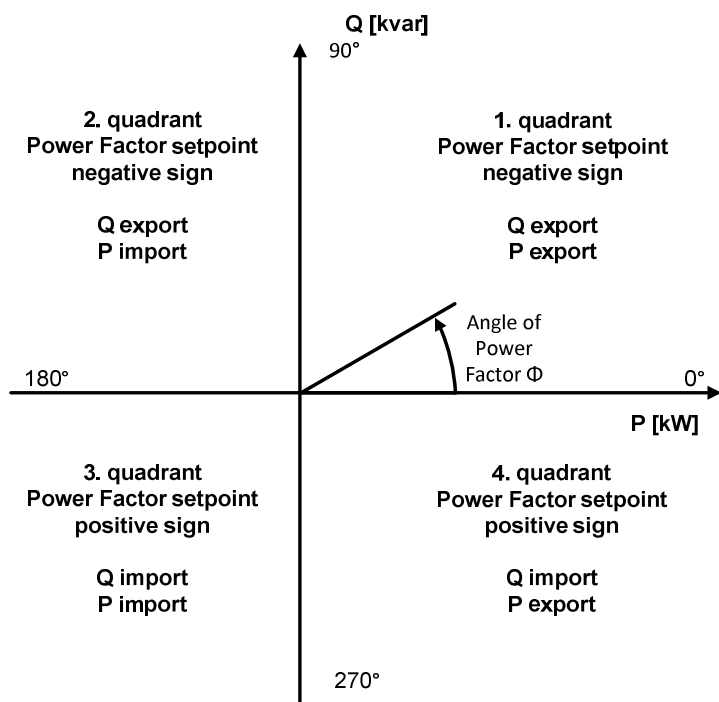

Figure 1 Definition of sign for active power, reactive power, Power Factor set points and reference for Power Factor angle.

The sign convention used for *Power Factor* can either comply with the specifications in IEEE 1459:2010 [ref. 29] or IEC TR 61850-90-7:2013 [ref. 26]. The *plant* documentation must specify which specification is used in the given *plant*.

#### 1.2.14 Harmonic distortions

*Harmonic distortions* are defined as electrical distortions caused by overharmonic currents and voltages. *Harmonic distortions* are also referred to as overtones, overharmonic tones, overharmonic distortion or simply harmonics. See section 4.5 for more detail.

#### 1.2.15 Interconnected electricity supply system

The *public electricity supply grids* and associated *plants* in a larger area which are interconnected for the purpose of joint operation are referred to as an *interconnected electricity supply system*.

#### 1.2.16 Nominal voltage ( $U_n$ )

The voltage at the *POC* for which a grid is defined and to which operational characteristics refer. The voltage is measured phase to phase. *Nominal voltage* is denoted by  $U_n$ .

The internationally standardised voltage levels are shown in Table 1.

#### 1.2.17 Normal operating voltage ( $U_c$ )

*Normal operating voltage* indicates the voltage range within which an *electricity-generating unit* must be able to continuously generate the specified *rated power*, see section 3.1 and section 3.2. *Normal operating voltage* is

denoted by  $U_c$ . *Normal operating voltage* is determined by the *electricity supply undertaking* and is used to determine the *normal production range*.

### 1.2.18 Normal production

*Normal production* indicates the voltage/frequency range within which a *PV power plant* must be able to continuously generate the specified *rated power*, see sections 3.1 and section 3.2.

### 1.2.19 Partial Weighted Harmonic Distortion (PWHD)

The *Partial Weighted Harmonic Distortions* are defined as the ratio between the root-mean-square (RMS) value of the current  $I_h$  or the voltage  $U_h$  for the h'th harmonic of a selected group of higher harmonics (h: 14th-40th harmonic) and the root-mean-square value (RMS) of the current  $I_1$  from the fundamental frequency. The general formula for *PWHD* is as follows:

$$PWHD = \sqrt{\sum_{h=14}^{h=40} h * \left(\frac{X_h}{X_1}\right)^2} \quad \text{See IEC 61000-3-12 [ref. 22] for more detail}$$

where:

X represents either current or voltage

$X_1$  is the RMS value of the fundamental component

h is the harmonic order

$X_h$  is the RMS value of the harmonic component of the h order.

### 1.2.20 Plant

A *plant* is one or more *electricity-generating units*, which are defined in more detail in section 1.2.9. In a PV context, the term *PV power plant* is often used for a *plant*, which is defined in more detail in section 1.2.37.

### 1.2.21 Plant categories

*Plant categories* in relation to the total *rated power* in the *Point of Connection*:

- A2. *Plants* above 11 kW up to and including 50 kW
- B. *Plants* above 50 kW up to and including 1.5 MW
- C. *Plants* above 1.5 MW up to and including 25 MW
- D. *Plants* above 25 MW or connected to over 100 kV.

### 1.2.22 Plant component

A *plant component* is a component or subsystem which is part of an overall *plant*.

### 1.2.23 Plant controller

A *plant controller* is a set of control functions that make it possible to control a *PV power plant* as a single *plant* in the *Point of Connection*. The set of control functions must be part of the *PV power plant* in a communicative context. This means that if communication to a *plant* is interrupted, it must be able to run as described in section 6.3, protected only by the safety settings.

#### **1.2.24 Plant infrastructure**

The *plant infrastructure* is the electrical infrastructure between the *Point of Generator Connection (PGC)* of the individual *electricity-generating units* in a *plant* and up to the *Point of Connection (POC)*.

#### **1.2.25 Plant operator**

The *plant operator* is the enterprise responsible for the operation of the *PV power plant*, either through ownership or contractual obligations.

#### **1.2.26 Plant owner**

The *plant owner* is the legal unit that owns a *plant*. In certain situations, the term company is used instead of *plant owner*. The *plant owner* may hand over the operational responsibility to a *plant operator*.

#### **1.2.27 Point of Common Coupling (PCC)**

The *Point of Common Coupling (PCC)* is the point in the *public electricity supply grid* where consumers are, or can be, connected.

The *Point of Common Coupling* and the *Point of Connection* may electrically coincide. The *Point of Common Coupling (PCC)* is always located farthest into the *public electricity supply grid*, ie furthest away from the *plant*, see Figure 2 and Figure 3.

The *electricity supply undertaking* determines the *Point of Common Coupling*.

#### **1.2.28 Point of Communication (PCOM)**

The *Point of Communication (PCOM)* is the point in a *plant*, where the data communication properties specified in section 7 must be made available and verified.

#### **1.2.29 Point of Connection (POC)**

The *Point of Connection (POC)* is the point in the public electricity supply grid where a *PV power plant* is, or can be, connected, see Figure 2 and Figure 3 for the typical location.

All requirements specified in this regulation apply to the *Point of Connection*. By agreement with the *electricity supply undertaking*, reactive compensation at no load can be placed elsewhere in the *public electricity supply grid*. The *electricity supply undertaking* determines the *Point of Connection*.

Figure 2 shows a typical installation connection of one or more *PV power plants* indicating the typical location of the *Point of Generator Connection (PGC)*, *Point of Connection (POC)*, *Point of Connection in Installation (PCI)* and *Point of Common Coupling (PCC)*. In the example below, the *Point of Common Coupling (PCC)* and the *Point of Connection (POC)* coincide.

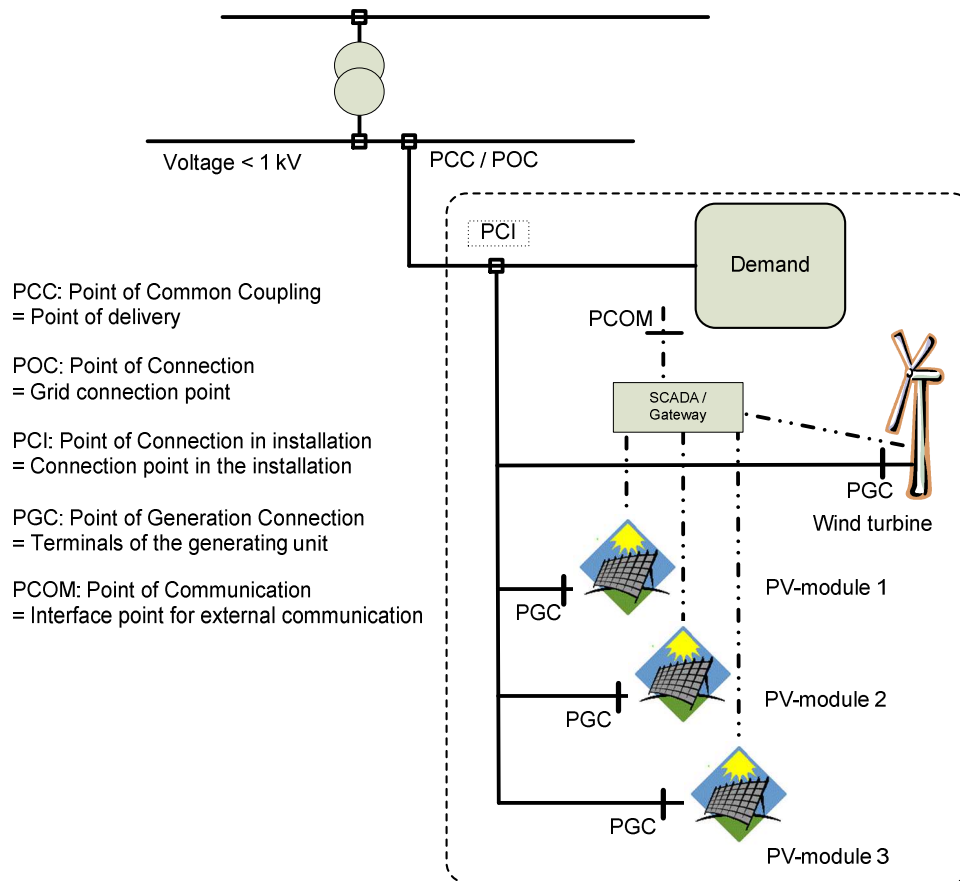

Figure 2 Example of installation connection of a PV power plant.

Figure 3 shows a typical connection of a PV power plant indicating the typical location of the Point of Common Coupling (PCC), Point of Connection (POC) and the voltage reference point.



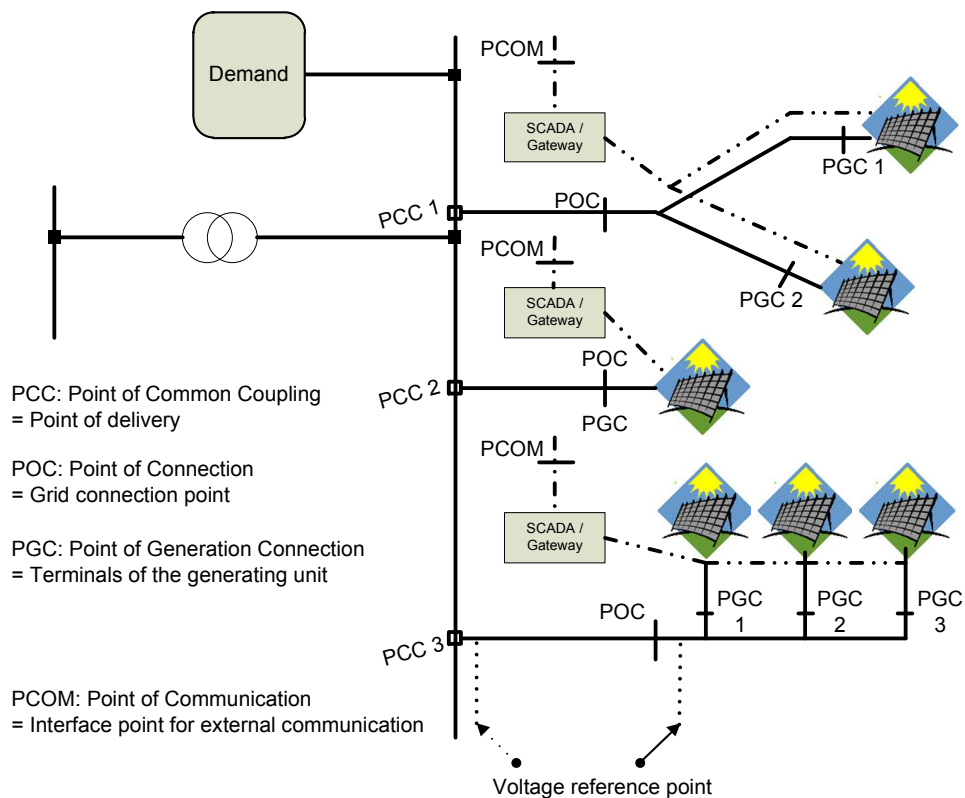

Figure 3 Example of connection of a PV power plant.

### 1.2.30 Point of Connection in Installation (PCI)

The *Point of Connection in Installation (PCI)* is the point in the installation where *electricity-generating units* in the installation are connected or can be connected; see Figure 2 for the typical location.

### 1.2.31 Point of Generator Connection (PGC)

The *Point of Generator Connection* is the point in the *plant infrastructure* where the terminals/generator terminals for the *electricity-generating unit* are located. The *Point of Generator Connection* for the *electricity-generating unit* is the point defined by the manufacturer as the *electricity-generating unit's* terminals.

### 1.2.32 Positive list

A so-called *positive list* has been prepared to facilitate the technical approval process for connection of a category A2 *plants*. The list contains *plant components* deemed to comply with the specific property and functionality requirements under the relevant technical regulations.

The *positive list* is available at the Danish Energy Association's website:  
[www.danskenergi.dk/positivlister](http://www.danskenergi.dk/positivlister).

### 1.2.33 Power Factor (PF)

*Power Factor*, cosine  $\varphi$ , for AC voltage systems indicates the ratio of active power  $P$  to apparent power  $S$ , where  $P = S \cdot \cos \varphi$ . Likewise, reactive power  $Q = S \cdot \sin \varphi$ . The angle between current and voltage is denoted by  $\varphi$ .

### 1.2.34 Power Factor control

*Power Factor control* is the control of reactive power proportionately to active power generated. See section 5.3.2 for more detail.

### 1.2.35 Power infrastructure

The *power infrastructure* is the part of the *public electricity supply grid* that connects the *POC* and *PCC*.

### 1.2.36 Public electricity supply grid

Transmission and distribution grids that serve to transmit electricity for an indefinite group of electricity suppliers and consumers on the terms laid down by public authorities.

The distribution grid is defined as the *public electricity supply grid* with a **maximum nominal voltage** of 100 kV.

The transmission grid is defined as the *public electricity supply grid* with a **nominal voltage above** 100 kV.

### 1.2.37 PV power plants

A *PV power plant* consists of one or more *electricity-generating units* (PV panels) with a total *rated power* above 11 kW, and is connected to the *public electricity supply grid*. The term *PV power plant* is equivalent to the term *plant*. *Electricity-generating unit* is defined in detail in section 1.2.9.

A *PV power plant* comprises all necessary power supply units and auxiliary facilities, and for this reason the entire *plant* must comply with the technical minimum requirements specified in this regulation.

A *PV power plant* has only one *Point of Connection*.

### 1.2.38 Q control

*Q control* is the control of reactive power, independent of active power generated.

### 1.2.39 Ramp rate constraint

The *ramp rate constraint* controls the interval of active power with a set point-defined maximum increase/reduction (ramp rate) of the active power. See section 5.2.3.3 for more detail.

### 1.2.40 Rapid voltage changes

*Rapid voltage change* is defined as a brief isolated voltage change (RMS). *Rapid voltage changes* are expressed as a percentage of *normal operating voltage*.

### 1.2.41 Rated current ( $I_n$ )

*Rated current*  $I_n$  is defined as the maximum continuous current that a *PV power plant* is designed to provide under normal operating conditions, see DSF/CLC/FprTS 50549-1:2014 [ref. 14] and DSF/CLC/FprTS 50549-2:2014 [ref. 15]. *Rated current* is denoted by  $I_n$ .

**1.2.42 Rated power of a PV power plant ( $P_n$ )**

The *rated power of a PV power plant* is the highest level of active power that the *PV power plant* is designed to continuously provide and that appears from the type approval. The *rated power* is denoted by  $P_n$ .

**1.2.43 Rated value for the apparent power ( $S_n$ ) of a PV power plant**

The *rated value for the apparent power  $S_n$*  is the highest power, consisting of both the active and reactive component, which a *PV power plant* is designed to continuously produce.

**1.2.44 Short circuit power ( $S_k$ )**

The *short circuit power  $S_k$*  is the level of three-phase *short circuit power* in the *Point of Connection*.

**1.2.45 Short circuit ratio (SCR)**

The *short circuit ratio (SCR)* is the ratio between the *short circuit power* in the *Point of Connection  $S_k$*  and the *plant's nominal apparent power  $S_n$* .

**1.2.46 Total Harmonic Distortion (THD)**

The *Total Harmonic Distortion* is defined as the ratio between the root-mean-square value (RMS) of the current  $I_h$  or the voltage  $U_h$  for the h'th (h: 2-40) harmonic and the root-mean-square value (RMS) of the current  $I_1$  from the fundamental frequency. The general formula for *THD* is as follows:

$$THD_I = \sqrt{\sum_{h=2}^{h=H} \left( \frac{X_h}{X_1} \right)^2} \quad \text{See IEC 61000-3-6 [ref. 19] for more detail}$$

where:

X represents either current or voltage

$X_1$  is the RMS value of the fundamental component

h is the harmonic order

$X_h$  is the RMS value of the harmonic component of the h order

H is generally 40 or 50 depending on use.

**1.2.47 Transmission system operator**

Enterprise entrusted with the overall responsibility for maintaining security of supply and ensuring the effective utilisation of an *interconnected electricity supply system*.

**1.2.48 Voltage control**

*Voltage control* is the control of reactive power with the configured *droop* to achieve the desired voltage in the *voltage reference point*.

**1.2.49 Voltage fluctuation**

A *voltage fluctuation* is a series of *rapid voltage changes* or a periodic variation of the root-mean-square (RMS) value of the voltage.

**1.2.50 Voltage reference point**

Metering point used for *voltage control*. The *voltage reference point* is either in the *Point of Connection*, the *Point of Common Coupling* or a point in between.

## 2. Objective, scope of application and regulatory provisions

### 2.1 Objective

The objective of Technical regulation TR 3.2.2 is to specify the minimum technical and functional requirements that a *PV power plant* with a *rated power* above 11 kW must comply with in the *Point of Connection* when the *PV power plant* is connected to the *public electricity supply grid*.

The regulation is issued pursuant to Section 7(1)(i), (iii) and (iv) of Danish Executive Order no. 891 of 17 August 2011 (Executive Order on transmission system operation and the use of the electricity transmission grid, etc. (Systemansvarsbekendtgørelsen)). Under Section 7(1) of the Executive Order on transmission system operation and the use of the electricity transmission grid, etc., this regulation has been prepared following discussions with grid companies and transmission enterprises. It has also been subject to public consultation before being registered with the Danish Energy Regulatory Authority.

This regulation is effective within the framework of the Danish Electricity Supply Act (Elforsyningsloven), see Consolidated Act no. 1329 of 25 November 2013 as amended.

A *PV power plant* must comply with Danish legislation, including the Danish Heavy Current Regulation (Stærkstrømsbekendtgørelsen) [ref. 4], [ref. 5], the Joint Regulation [ref. 3], the Machinery Directive [ref. 6], [ref. 7] as well as the grid connection and grid use agreement.

In areas which are not subject to Danish legislation, CENELEC standards (EN), IEC standards, CENELEC or IEC technical specifications apply.

### 2.2 Scope of application

Throughout its lifetime, a *PV power plant* connected to the *public electricity supply grid* must comply with the provisions of this regulation.

The technical requirements of the regulation are divided into the following categories based on the total *rated power* in the *Point of Connection*:

- A2. *Plants* above 11 kW up to and including 50 kW (\*\*)
- B. *Plants* above 50 kW up to and including 1.5 MW
- C. *Plants* above 1.5 MW up to and including 25 MW
- D. *Plants* above 25 MW or connected to over 100 kV.

\*\*) *Plant components* used in this *plant category* may be included in the *positive list of plant components* or *plants* which may be installed in Denmark.

All requirements in this regulation respect the *plants'* design framework and properties that the current *PV power plant* technology offers, including properties at different solar radiation conditions.

For planning and grid expansion reasons, *the electricity supply undertaking* has the right to reject grid connection for non-three-phase *plant*.

### 2.2.1 New PV power plants

This regulation applies to all *PV power plants* with *rated power* above 11 kW, connected to the *public electricity supply grid* and commissioned as of the effective date of this regulation.

### 2.2.2 Existing PV power plants

A *PV power plant* with a *rated power* above 11 kW which was connected to the *public electricity supply grid* before the effective date of this regulation must comply with the regulation in force at the time of commissioning.

### 2.2.3 Modifications to existing PV power plants

If substantial functional modifications are made to an existing *PV power plant*, this *plant* must comply with the provisions of this regulation relating to such modifications. In case of doubt, the *transmission system operator* decides whether a specific modification is substantial.

A substantial modification is the replacement of one or more vital *plant components* which changes the *properties* of the PV power plant.

The documentation described in section 8 must be updated and submitted in a version showing any modifications made.

## 2.3 Delimitation

This technical regulation is part of the complete set of technical regulations issued by the Danish *transmission system operator*, Energinet.dk.

The technical regulations contain the technical minimum requirements that apply to the *plant owner*, *plant operator* and *electricity supply undertaking* regarding the operation and connection of *plants* to the *public electricity supply grid*.

Together with the market regulations, the technical regulations, including the system operation regulations, constitute the set of rules to be complied with by the *plant owner*, *plant operator* and *electricity supply undertaking*:

- Technical regulation TR 5.8.1 'Metering data for system operation purposes' [ref. 10]
- Technical regulation TR 5.9.1 'Ancillary services' [ref. 11]
- Regulation D1 'Settlement metering' [ref. 12]
- Regulation D2 'Technical requirements for electricity metering' [ref. 13]
- Technical regulation TR 3.2.2 'Technical regulation for grid connection of *PV power plants* with a power output above 11 kW'.

Current versions of the above-mentioned documents are available at Energinet.dk's website [www.energinet.dk](http://www.energinet.dk).

Operational matters will be agreed between the *plant owner* and the *electricity supply undertaking* within the framework set by the *transmission system operator*.

In case of any discrepancy between the requirements of the individual regulations, the *transmission system operator* decides which requirements should apply.

Any supply of ancillary services must be agreed between the *plant owner* and the *balance-responsible party for production*.

This regulation does not deal with the financial aspects of using control capabilities, settlement metering or technical settlement metering requirements.

The *plant owner* must safeguard the *PV power plant* against possible damaging impacts due to a lack of electricity supply from the *public electricity supply grid* for short or long periods of time.

## 2.4 Statutory authority

This regulation is issued pursuant to:

- Section 26(1) of Consolidated Act no. 1329 of 25 November 2013 concerning the Danish Electricity Supply Act
- Section 7(1), (i), (iii) and (iv) of Danish Executive Order no. 891 of 17 August 2011 (Executive Order on transmission system operation and the use of the electricity transmission grid, etc.)

## 2.5 Effective date

This regulation comes into force on **14 July 2016** and replaces

- Technical regulation 3.2.2 for PV power plants with a power output above 11 kW, Revision 2, effective from 24 July 2015.

Please direct questions and requests for additional information on this technical regulation to Energinet.dk. Contact information is available at <http://energinet.dk/EN/El/Forskrifter/Technical-regulations/Sider/Regulations-for-grid-connection.aspx>.

The regulation was registered with the Danish Energy Regulatory Authority pursuant to the provisions of Section 26 of the Danish Electricity Supply Act (Elforsyningsloven) and Section 7 of the Danish Executive Order on transmission system operation and the use of the electricity transmission grid, etc. (Systemansvarsbekendtgørelsen).

As regards *PV power plants*, the construction of which was finally ordered in a binding written order before the regulation was registered with the Danish Energy Regulatory Authority but which are scheduled to be commissioned after this regulation becomes effective, an exemption can be applied for in accordance with section 2.9, enclosing any relevant documentation.

## 2.6 Complaints

Complaints in respect of this regulation may be lodged with the Danish Energy Regulatory Authority, [www.energitilsynet.dk](http://www.energitilsynet.dk).

Complaints about the *transmission system operator's* enforcement of the provisions of the regulation can also be lodged with the Danish Energy Regulatory Authority.

Complaints about how the individual *electricity supply undertaking* enforces the provisions of the regulation can be lodged with the *transmission system operator*.

## 2.7 Breach

The *plant owner* shall ensure that the provisions of this regulation are complied with throughout the life of the *PV power plant*.

The *plant owner* must pay any expenses incurred to ensure compliance with the provisions of this regulation.

## 2.8 Sanctions

If a *PV power plant* does not comply with the provisions of sections 3 to 9 of this regulation, the *electricity supply undertaking* is entitled to cut off the grid connection to the *PV power plant* as a last resort, subject to the decision made by Energinet.dk, until the provisions are complied with.

## 2.9 Exemptions and unforeseen events

The *transmission system operator* may grant exemption from specific requirements in this regulation.

An exemption can only be granted if:

- special conditions exist, for instance of a local nature
- the deviation does not impair the technical quality and balance of the *public electricity supply grid*
- the deviation is not inappropriate from a socio-economic viewpoint.

To obtain an exemption, a written application must be submitted to the *electricity supply undertaking*, stating which provisions the exemption concerns and the reason for the exemption.

The *electricity supply undertaking* has the right to comment on the application before it is submitted to the *transmission system operator*.

If events not foreseen in this technical regulation occur, the *transmission system operator* must consult the parties involved to agree on a course of action.

If an agreement cannot be reached, the *transmission system operator* must decide on a course of action. The decision must be based on what is reasonable, where possible taking the views of the parties involved into consideration.

Complaints about the decisions of the *transmission system operator* can be lodged with the Danish Energy Regulatory Authority, see section 2.6.

## 2.10 References

The standards listed are only to be used in relation to the topics mentioned in connection with the references in this regulation.

### 2.10.1 Normative references

1. **DS/EN50160:2010**: Voltage characteristics of electricity supplied by public distribution networks.
2. **DS/EN 60038:2011**: IEC/CENELEC standard voltages.
3. **Joint Regulation 2014**: 'Connection of electrical equipment and utility products'.

4. **Section 6 of the Danish Heavy Current Regulation:** 'Electrical installations', 2003.
5. **Section 2 of the Danish Heavy Current Regulation:** 'Design of electricity supply systems', 2003.
6. **DS/EN 60204-1:2006:** Safety of machines – Electrical equipment of machines.
7. **DS/EN 60204-11:2002:** Safety of machinery – Electrical equipment of machines – Part 11: Requirements for HV equipment for voltages above 1000 V a.c. or 1500 V d.c. and not exceeding 36 kV.
8. **IEC 60870-5-104:2007:** Telecontrol equipment and systems, Part 5-104.
9. **IEC 61000-4-15:2010:** Testing and measurement techniques – Section 15: *Flicker* metre – Functional and design specifications.
10. **Technical regulation TR 5.8.1:** 'Måledata til systemdriftsformål' (Metering data for system operation purposes), dated 28 June 2011, Rev. 3.0, doc. no. 17792/10 (= new doc. no. 13/89692-218).
11. **Technical regulation TR 5.9.1:** 'Systemtjenester' (Ancillary services), dated 5 July 2012, Rev. 1.1, doc. no. 91470-11 (= new doc. no. 13/89692-225).
12. **Regulation D1:** 'Settlement metering', dated March 2013, Rev. 3.1, doc. no. 13/81271-2.
13. **Regulation D2:** 'Technical requirements for electricity metering', dated May 2007, Rev. 1, doc. no. 171964-07 (= new doc. no. 13/91893-11).
14. **DS/CLC/TS 50549-1:2014:** Requirements for generating plants to be connected in parallel with a distribution network – Part 1: Generating plants larger than 16A per phase to be connected with a low voltage network.
15. **DS/CLC/TS 50549-2:2014:** Requirements for generating plants to be connected in parallel with a distribution network – Part 2: Generating plants to be connected with a medium voltage network.
16. **IEC 60050-415:1999:** International Electrotechnical Vocabulary.
17. **DS/EN 61000-3-2:2014:** Limit values – Limit values for harmonic current emissions (equipment input current up to and including 16A per phase).
18. **DS/EN 61000-3-3:2013:** Limit values – Limitation of voltage fluctuations and flicker in public low-voltage supply systems, from equipment with a rated current  $\leq 16A$  per phase which is not subject to conditional connection rules.
19. **IEC/TR 61000-3-6:2008:** EMC limits. Limitation of emissions of harmonic currents for equipment connected to medium and high voltage power supply systems.
20. **IEC/TR 61000-3-7:2008:** EMC limits. Limitation of voltage fluctuations and flicker for equipment connected to medium and high voltage power supply systems.
21. **DS/EN 61000-3-11:2001:** Electromagnetic compatibility (EMC): Limitation of voltage changes, voltage fluctuations and flicker in public low-voltage supply systems – Equipment with a rated current up to and including 75A which is subject to conditional connection.
22. **DS/EN 61000-3-12:2012:** Limits – Limits for harmonic currents produced by equipment connected to public low-voltage systems with input current  $> 16A$  and  $\leq 75A$  per phase.
23. **IEC/TR 61000-3-13:2008:** Electromagnetic compatibility (EMC): Limits – Assessment of emission limits for the connection of unbalanced installations to MV, HV and EHV power systems.
24. **IEC/TR 61000-3-14:2011:** Electromagnetic compatibility (EMC): Assessment of emission limits for harmonics, interharmonics, voltage



fluctuations and unbalance for the connection of disturbing installations to LV power systems.

25. **IEC/TR 61000-3-15 Ed. 1.0:2011**: Limits – Assessment of low frequency electromagnetic immunity and emission requirements for dispersed generation systems in LV network.
26. **IEC/TR 61850-90-7:2013**: Object models for power converters in distributed energy resources (DER) systems.
27. **IEC 61850-8-1 Ed2:2011**: Mappings to MMS (ISO/IEC9506-1 and ISO/IEC 9506-2).
28. **IEC 61400-21Ed2: 2008**: Measurement and assessment of power quality characteristics of grid connected wind turbines.
29. **IEEE 1459:2010**: Standard definitions for the measurement of electrical power quantities under sinusoidal, non-sinusoidal, balanced or unbalanced conditions.
30. **VDE-AR-N 4105:2011-8**: Power generation systems connected to the low voltage distribution network.

### 2.10.2 Informative references

31. **Research Association of the Danish Electric Utilities (DEFU) report RA-557**: 'Maximum emission of voltage disturbances from *PV power plants* with a power output above 11 kW'.
32. **Research Association of the Danish Electric Utilities recommendation no. 16**: Voltage quality in low-voltage grids, 2nd edition, June 2001.
33. **Research Association of the Danish Electric Utilities recommendation no. 21**: Voltage quality in medium-voltage grids, February 1995.
34. **COMTRADE**: File format specified in IEEE C37.111-2013.
35. **SunSpec Inverter Control specifications**: [www.sunspec.org](http://www.sunspec.org).
36. **Guidelines for supplier statement – TR 3.2.2**, document no. 14/17997-18.
37. **Guidelines on the calculation of power quality parameters – TR 3.2.2**, document no. 14/17997-16.
38. **Guidelines on verification report – TR 3.2.2**, document no. 14/17997-15.
39. **Guidelines on signal list – TR 3.2.2**, document no. 14/17997-19.

### 3. Tolerance of frequency and voltage deviations

A *PV power plant* must be able to withstand frequency and voltage deviations in the *Point of Connection* under normal and abnormal operating conditions while reducing the active power as little as possible.

All requirements outlined in the following sections are to be considered minimum requirements.

For planning and grid expansion reasons, the *electricity supply undertaking* has the right to reject grid connection for *plants* which are not three-phase.

Normal operating conditions are described in section 3.2, and abnormal operating conditions are described in section 3.3.

#### 3.1 Determination of voltage level

The *electricity supply undertaking* determines the voltage level for the *PV power plant's Point of Connection* within the voltage limits stated in Table 1.

The *normal operating voltage* may differ from location to location, and the *electricity supply undertaking* must therefore state the *normal operating voltage*  $U_c$  for the *Point of Connection*. The *normal operating voltage* forms the basis for determining the *normal operating voltage range*  $U_c \pm 10\%$ .

The *electricity supply undertaking* must ensure that the maximum voltage stated in Table 1 is never exceeded.

If the *normal operating voltage range*  $U_c \pm 10\%$  is lower than the minimum voltage stated in Table 1, the output requirements in the event of frequency and voltage variations must be adjusted so as not to overload the *PV power plant*.

Voltage level descriptions	Nominal voltage $U_n$ [kV]	Minimum voltage $U_{min}$ [kV]	Maximum voltage $U_{max}$ [kV]
Extra high voltage (EH)	400	320	420
	220	-	245
High voltage (HV)	150	135	170
	132	119	145
	60	54.0	72.5
	50	45.0	60.0
Medium voltage (MV)	33	30.0	36.0
	30	27.0	36.0
	20	18.0	24.0
	15	13.5	13.5
	10	9.00	12.0
Low voltage (LV)	0.69	0.62	0.76
	0.40	0.36	0.44

Table 1 Definition of voltage levels used in this regulation.

Maximum ( $U_{max}$ ) and minimum ( $U_{min}$ ) voltage limits are determined using the standards DS/EN 50160 (10-minute mean values) [ref. 1] and DS/EN 60038 [ref. 2].

The *PV power plant* must be able to briefly withstand voltages exceeding the maximum voltages within the required protective functions as specified in section 6.

### 3.2 Normal operating conditions

Within the *normal production range*, a *PV power plant* must be designed to start and generate power continuously within the design specifications (eg that incoming solar radiation has the correct characteristics), restricted only by the settings of the protective function as described in section 6 and/or other functions impacting the *plant's* output.

Within the *normal production range*, the *normal operating voltage* is  $U_c \pm 10\%$ , see section 3.1, and the frequency range is 47.00 to 52.00 Hz.

Automatic connection of a *PV power plant* can take place no earlier than three minutes after the voltage and frequency have come within the *normal production range*.

Frequency limit settings are determined by *the transmission system operator*.

#### 3.2.1 Normal production requirements

The overall requirements for active power production in the event of frequency and voltage deviations that a *PV power plant* in the *Point of Connection (POC)* must comply with are shown in the figure below. In the  $U_c + 10\%$  to  $U_c$  voltage range, the active power is limited to the nominal output. In the  $U_c$  to  $U_{min}$  voltage range, the active power is limited by the potential nominal current.

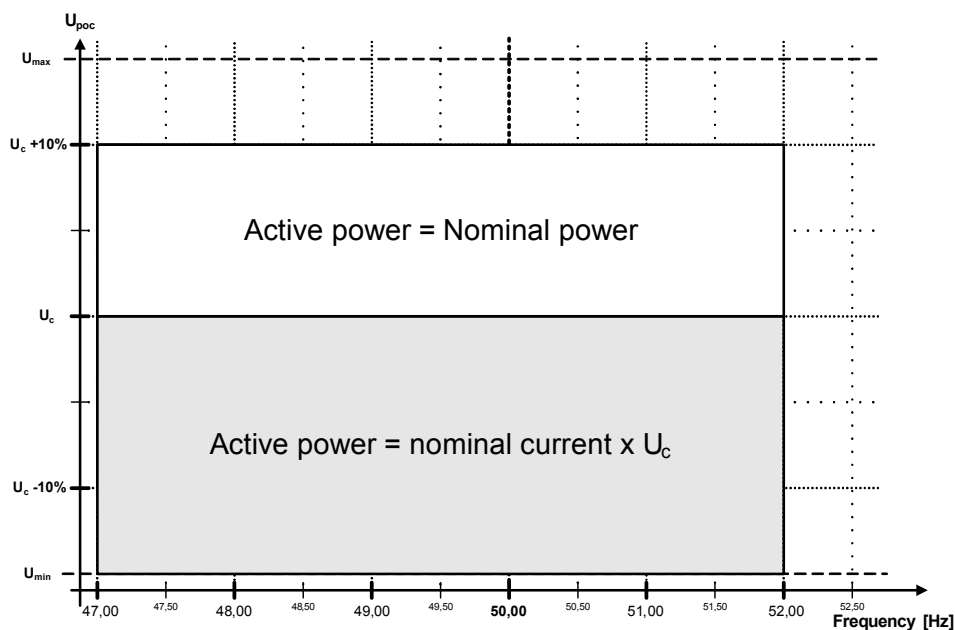

Figure 4 Requirements for active power production in the event of frequency and voltage fluctuations.

The *PV power plant* must remain connected to the *public electricity supply grid* in accordance with the required settings for protective functions as specified section 6.

### 3.3 Abnormal operating conditions

The following requirements apply to category C and D *PV power plants*.

The *PV power plant* must be designed to withstand transitory (80-100 ms) phase jumps of up to 20° in the *Point of Connection (POC)* without disrupting or reducing its output.

The *PV power plant* must be designed to withstand a voltage dip as shown in Figure 5 without disruptions, and generate additional reactive current as stated in Figure 6 during the fault sequence.

During a voltage dip, the output is determined by the nominal current.

After a transient start-up period, the *PV power plant* must be capable of delivering *normal production* no later than five seconds after the operating conditions in the *Point of Connection* have reverted to the *normal production* range.

Irrespective of the requirements outlined in the following sections, the protective settings must be set as specified in section 6.

Documentation proving that the *PV power plant* complies with the specified requirements must be set as specified in section 8.

The *PV power plant* must be protected against damage caused by out-of-phase reclosing and against disconnections in non-critical situations.

#### 3.3.1 Voltage dip tolerance

In the *Point of Connection*, a *PV power plant* must be designed to withstand voltage dips down to 10% of the voltage in the *Point of Connection* over a period of minimum 250 ms (line-to-line voltages for the 50 Hz component), as shown in Figure 5, without disconnecting.

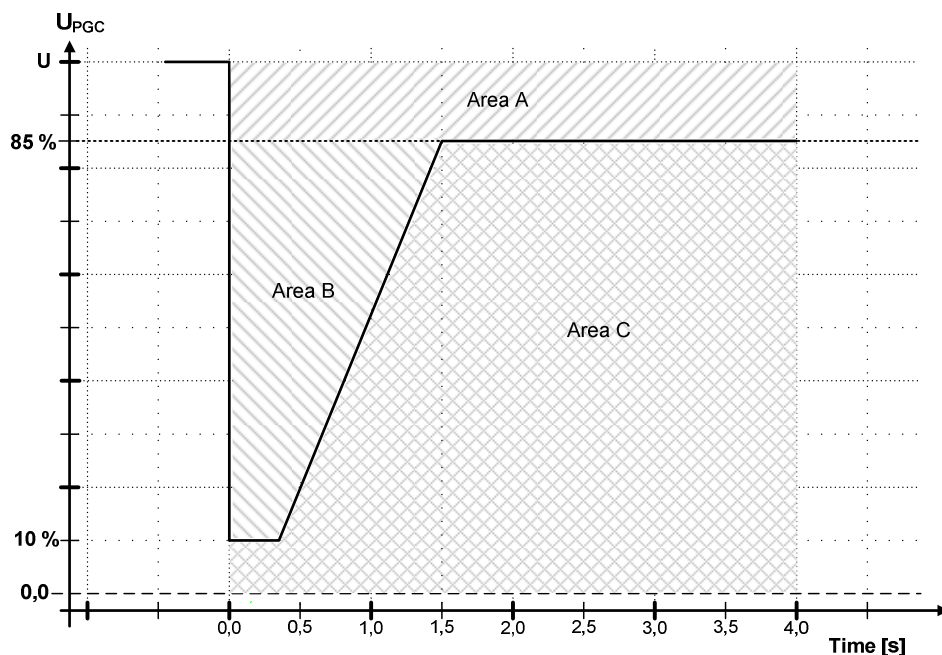

Figure 5 Voltage dip tolerance requirements for category C and D PV power plants.

The following requirements must be complied with in the event of symmetrical and asymmetrical faults. This means that the requirements apply in the event of faults in three, two or a single phase:

- Area A: The PV power plant must stay connected to the grid and maintain normal production.
- Area B: The PV power plant must stay connected to the grid. The PV power plant must provide maximum voltage support by delivering a controlled amount of additional reactive current so as to ensure that the PV power plant contributes to stabilising the voltage within the design framework offered by the current PV power plant technology, see Figure 5.
- Area C: Disconnection of the PV power plant is permitted.

If the voltage  $U_{POC}$  reverts to area A during a fault sequence, a subsequent voltage dip will be regarded as a new fault situation, see section 3.3.2.

If several successive fault sequences occur within area B and continue into area C, timewise, then disconnection is allowed.

In connection with fault sequences in area B, the PV power plant must have a control function capable of controlling the positive sequence of the reactive current as specified in Figure 6.

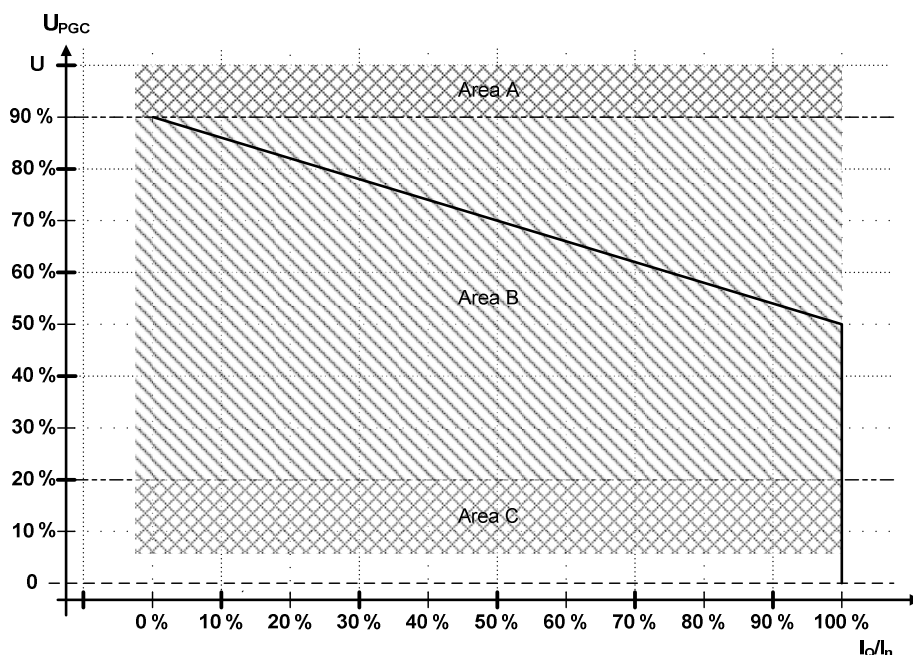

Figure 6 Requirements for the delivery of additional reactive current  $I_Q$  during voltage dips for category C and D PV power plants.

Control must follow Figure 6 so that the additional reactive current (positive sequence) follows the characteristic with a tolerance of  $\pm 20\%$  after max. 100 ms.

In area B, the delivery of reactive current takes first priority, while the delivery of active power takes second priority.

If possible, active power must be maintained during a voltage dip, although a reduction in active power within the *PV power plant's* design specifications is acceptable, including limitations caused by changes in solar radiation.

Fault types may be symmetrical and asymmetrical short circuits, recurring voltages when faults and incidents are disconnected, as well as increased voltage on fault-free phases in the event of asymmetrical short circuits.

### 3.3.2 Recurring faults in the public electricity supply grid

The *PV power plant* and any compensation equipment must stay connected during and after faults have occurred in the *public electricity supply grid* as specified in Table 2.

These requirements apply to the *Point of Connection*, but the fault sequence is at a random point in the *public electricity supply grid*.

To further ensure compliance with the voltage dip requirements stated in section 3.3.1, the requirements in Table 2 must be verified by documenting that the *PV power plant* is designed to withstand recurring faults with the specifications stated.

<b>Type</b>	<b>Duration of fault</b>
Three-phase short circuit	Short circuit for 150 ms
Phase-to-phase-to-earth short circuit/phase-to-phase short circuit	Short circuit for 150 ms followed by a new short circuit 0.5 to 3 seconds later, also with a duration of 150 ms
Phase-to-earth short circuit	Phase-to-earth fault for 150 ms followed by a new phase-to-earth fault 0.5 to 3 seconds later, also with a duration of 150 ms

*Table 2 Types and duration of faults in the public electricity supply grid.*

## 4. Power quality

### 4.1 General

When assessing a *PV power plant's* impact on power quality in the *public electricity supply grid*, the various power quality parameters in the *Point of Connection* must be documented.

The table below lists the distortion requirements in the individual *plant categories*.

<b>Requirements</b> \ <b>Category</b>	<b>A2</b>	<b>B</b>	<b>C</b>	<b>D</b>
DC content ( 4.2)	X	X	X	X
Asymmetry (4.3)	X	X	X	X
<i>Flicker</i> (4.4)	X	X	X	X
<i>Harmonic distortions</i> (4.5)	X	X	X	X
Interharmonic distortions (4.6)	-	X	X	X
Distortions 2-9 kHz (4.7)	-	X	X	X

The bracketed numbers in the individual rows indicate the sections in which the requirement are specified.

*Table 3 Overview of power quality requirements for plant categories.*

For each of these distortion types, the following is specified:

- Data basis used for calculations
- Emission limit values – *plant* requirements
- Methods for verifying compliance with limit values.

Applied power quality terminology and calculation methods are described in the following international standards: DS/EN 61000-3-2:2014 [ref. 17], DS/EN 61000-3-3:2013 [ref. 18], IEC/TR 61000-3-6:2008 [ref. 19], IEC/TR 61000-3-7:2008 [ref. 20], DS/EN 61000-3-11 [ref.21], DS/EN 61000-3-12 [ref. 22], DS/EN 61000-3-13 [ref. 23], DS/EN 61000-3-14 [ref. 24] and DS/EN 61000-3-15 [ref. 25] as well as national recommendations in the Research Association of the Danish Electric Utilities recommendation no. 16 [ref. 32] and the Research Association of the Danish Electric Utilities recommendation no. 21 [ref. 33].

The *electricity supply undertaking* is responsible for setting emission limits in the *Point of Connection*.

The *electricity supply undertaking* must agree on a schedule for determining emission limits with grid connection applicants.

Generally, the *plant owner* must ensure that the *PV power plant* is designed, constructed and configured in observance of the specified emission limits without grid reinforcements being required.

The *plant owner* may, according to agreement, purchase supplementary services from the *electricity supply undertaking* to ensure compliance with the specified limit values.



The *plant owner* must verify compliance with the emission limits in the *Point of Connection*.

#### 4.1.1 Data basis

Data for the *PV power plant* as well as the *public electricity supply grid* will be used to assess a *PV power plant's* impact on power quality.

The *plant owner* must provide data as specified in IEC 61400-21 [ref. 28] to determine the emission of *flicker* and high-frequency distortions for the *PV power plant*.

The *plant owner* must choose one of the following methods for the determination of the emission of *flicker* and high-frequency distortions.

1. The *plant owner* uses the results of the type test for each of the *electricity-generating units* that make up the *PV power plant*. The type test must be performed in accordance with the relevant parts of IEC 61400-21 [ref. 28]. Type tests meeting the specifications of VDE 4105 [ref. 30] are considered to fulfil the requirements.

The *plant owner* calculates the total emissions as the sum of the contributions from each of the *electricity-generating units* that make up the *plant*.

2. The *plant owner* develops an emission model for the *PV power plant*. The *plant owner* must thus document that this emission model can be used to determine the emission of high-frequency distortions from the entire *plant*.

The *plant* emission model must include emission models for the *electricity-generating units* and the *plant infrastructure* in the *Point of Connection* for the relevant frequency range.

The *transmission system operator* must approve the emission model

The *electricity supply undertaking* supplies data for the *public electricity supply grid* in the *Point of Connection*. As regards the calculation of *voltage fluctuations*, see current international standards, the *public electricity supply grid* can be defined by the minimum, typical and maximum *short circuit power*  $S_k$  and the corresponding grid impedance angle  $\psi_k$  in the *Point of Connection*.

The *electricity supply undertaking* must state the maximum, minimum and typical  $S_k$  for the *Point of Connection*.

#### 4.1.2 Limit values

The *electricity supply undertaking* is responsible for supplying limit values for the emission of the various types of distortions coming from the *PV power plant* in the *Point of Connection* so as to ensure that the limit values for power quality in the *public electricity supply grid* are not exceeded.

The limit values specified in this regulation have been determined on the basis of the specifications in the Research Association of the Danish Electric Utilities

recommendation no. 21 [ref. 33], IEC/TR 61000-3-6 [ref. 19], IEC/TR 61000-3-7 [ref. 20], DS/EN 61000-3-12 [ref. 22] and DS/EN 61000-3-11 [ref. 21].

#### 4.1.3 Verification

The *plant owner* must use calculation, simulation or measurement, to verify that the *PV power plant* complies with the limits defined in the *Point of Connection*. The *electricity supply undertaking* must approve the *plant owner's* verification.

#### 4.2 DC content

For all *plant categories*, the DC content of the supplied AC current in the *plant's Point of Connection (POC)* may not exceed 0.5% of the nominal current, see IEC/TS 61000-3-15, section 7.5 [ref. 25].

#### 4.3 Asymmetry

For all *plant categories*, the asymmetry between the phases at normal operation or in the event of faults in the *electricity-generating unit* may not exceed 16A.

#### 4.4 Flicker

##### 4.4.1 Data basis

*Flicker* emission must be documented for continuous operation. Document the *flicker* level using data from type tests or emission models.

When calculating the *flicker* contribution at continuous operation, use the *flicker* coefficient  $c_i(\psi_k)$  data that appear from the type test, where:  $C_i$ ,  $i$ : *electricity-generating unit* no.  $i$ .

##### 4.4.2 Limit values

The *PV power plant's* total *flicker* contribution must meet the requirements in the following sections in the *Point of Connection*.

###### 4.4.2.1 Requirements for category A2 PV power plants

The limit values for *plants* in this category are stated in the table below for emissions from the individual *PV power plant*, see DS/EN 61000-3-11, section 5 [ref. 21].

Voltage level	$P_{It}$
$U_n \leq 1$ kV	0.65

Table 4 Limit values for long-term flicker  $P_{It}$ .

###### 4.4.2.2 Requirements for category B PV power plants

If the connected *rated power* is lower than 0.4% of  $S_k$ , the *PV power plant* can be connected without further examinations.

Otherwise, the limit values in the following table apply to emissions from the individual *PV power plant*, see DS/EN 61000-3-11, section 5 [ref. 21].

Voltage level	$P_{st}$	$P_{lt}$
$U_n \leq 1 \text{ kV}$	0.35/0.45/0.55 <sup>*)</sup>	0.25/0.30/0.40 <sup>*)</sup>
$U_n > 1 \text{ kV}$	0.30	0.20

\*) The limit values apply if 4/2/1, respectively, generation facilities are already connected under the same substation.

Table 5 Limit values for short-term flicker  $P_{st}$  and long-term flicker  $P_{lt}$ .

#### 4.4.2.3 Requirements for category C and D PV power plants

The *electricity supply undertaking* determines the *flicker* emission limits in the *Point of Connection*, so that the maximum allowed *flicker* level  $G_{lt}$  and  $G_{st}$  at the same voltage level and under the same substation is not exceeded.

#### 4.4.3 Verification

Verify that the *flicker* emission from continuous operation of the *PV power plant* is below the limit value in the *Point of Connection*.

Determine the *flicker* coefficient on the basis of the current  $\psi_k$  for the *electricity-generating unit* through simple interpolation between the values for  $\psi_k$  specified in the type test.

The *flicker* emission for each *electricity-generating unit* that makes up the *PV power plant* is calculated as:

$$P_{lt,i} = c_i(\psi_k) \cdot \frac{S_{n,i}}{S_k}$$

The emission from the entire *PV power plant* is then calculated as:

$$P_{lt} = \sqrt[3]{\sum_i (P_{lt,i})^3}$$

Calculation examples can be found in 'Guidelines on the calculation of power quality parameters – TR 3.2.2' [ref. 37].

Alternatively, the verified emission model must be used.

#### 4.4.3.1 Category A2, B, C and D PV power plants

Verify that the *flicker* emission from continuous operation of the *PV power plant* is below the limit value in the *Point of Connection*.

### 4.5 Harmonic distortions

Emission of *harmonic distortions* must be documented for the entire *PV power plant*.

#### 4.5.1 Data basis

Use data from type tests or emission models to document the emission level.

The type test specifies measured mean values for 2nd-40th harmonic contributions for 11 levels of generated active power from 0% to 100% of the

rated power and with a power factor of 1. The measured mean values are stated as a percentage of the rated current.

#### 4.5.2 Limit values

The PV power plant is not allowed to emit harmonic distortions exceeding the limit values specified in this section.

For PV power plants which are connected far from other consumers, the emission limits may, however, be changed to values above the normal emission limits following acceptance from the electricity supply undertaking.

In addition to limit values for the individual harmonic distortions, limit values for THD and PWHD are used.

For category C and D PV power plants, limit values for the harmonic distortions are determined as voltage distortions in order to take into account local variations in the grid impedance. Account is also taken of the size of the plant relative to the capacity in the grid.

##### 4.5.2.1 Requirements for category A2 PV power plants

The limit values for harmonic current emissions for different orders  $h$  appear from the table below, see DS/EN 61000-3-12, Table 3 [ref. 22]. The requirements below assume that SCR is less than 33. If the short circuit ratio is different, reference is made to Table 3 of the above standard.

Harmonic	Odd harmonic order $h$ (not a multiple of 3)					Even harmonic order $h$		
	5	7	11	13	$17 \leq h \leq 39$	2	4	$8 \leq h \leq 40$
Limit value [%]	10.7	7.2	3.1	2	-	-	-	-

Table 6 Limit values for harmonic current  $I_h/I_n$  (% of  $I_n$ ) – A2.

The limit values for total harmonic current distortion emissions appear from the table below.

Voltage level	SCR	THD	PWHD
$U_c \leq 1$ kV	<33	13	22
$U_c > 1$ kV	-	No requirements	No requirements

Table 7 Limit values for total harmonic current distortion (% of  $I_h$ ) – A2.

##### 4.5.2.2 Requirements for category B PV power plants

The limit values for harmonic current emissions for different orders  $h$  appear from the table below, see DS/EN 61000-3-12, Table 3 [ref. 22].

Voltage level	SCR	Odd harmonic order h (not a multiple of 3)					Even harmonic order h		
		5	7	11	13	17≤h≤39	2	4	8≤h≤40
$U_c \leq 1$ kV	<33	3.6	2.5	1.0	0.7	-	-	-	-
	≥33	4.1	2.8	1.1	0.8	-	-	-	-
	≥66	5.3	3.5	1.7	1.2	-	-	-	-
	≥120	7.2	4.6	2.6	1.6	-	-	-	-
	≥250	11.7	7.5	4.4	3.0	-	-	-	-
	≥350	15.2	9.6	5.9	4.1	-	-	-	-
$U_c > 1$ kV	-	4.0	4.0	2.0	2.0	$\frac{400}{h^2}$ *)	0.8	0.2	0.1

\*) Though not less than 0.1%.

Note: Interpolation between the table values is required for  $SCR \geq 33$ .

Table 8 Limit values for harmonic current  $I_n/I_n$  (% of  $I_n$ ) – B.

The limit values for total harmonic current distortion emissions appear from the table below.

Voltage level	SCR	THD <sub>I</sub>	PWHD <sub>I</sub>
$U_c \leq 1$ kV	<33	4.5	7.9
	≥33	4.9	8.1
	≥66	6.0	9.0
	≥120	8.3	10.5
	≥250	13.9	14.3
	≥350	18.0	17.3
$U_c > 1$ kV	-	-	-

Table 9 Limit values for total harmonic current distortion (% of  $I_n$ ) – B.

#### 4.5.2.3 Requirements for category C and D PV power plants

The electricity supply undertaking determines the emission limits for harmonic distortions in the Point of Connection.

The emission limits must ensure that the total permissible noise level for the individual harmonic distortions and  $THD_U$  is not exceeded in the Point of Connection.

The limit values for total harmonic voltage distortion emissions appear from the table below.

Voltage level	THD <sub>U</sub>
$U_n \leq 35$ kV	6.5
$U_n > 35$ kV	3.0

Table 10 Limit values for total harmonic voltage distortion  $THD_U$  (% of  $U_n$ ).

#### 4.5.3 Verification

Verify that PV power plant emissions are below the limit value in the Point of Connection.

Therefore, the value from the level of generated active power at which the individual harmonic current is the greatest is used to verify observance of the limit values for harmonic currents for the individual harmonic currents  $h$ . Use the current values to calculate  $THD_I$  and  $PWHD_I$  for the verification of conformity with the limit values for  $THD_I$  and  $PWHD_I$ .

For current harmonic  $I_h$ ,  $THD_I$  and  $PWHD_I$  are defined as:

$$THD_I = \sqrt{\sum_{h=2}^{h=40} \left( \frac{I_h}{I_1} \right)^2} \quad [\text{ref. 19}] \quad \text{and} \quad PWHD_I = \sqrt{\sum_{h=14}^{h=40} h * \left( \frac{I_h}{I_1} \right)^2} \quad [\text{ref. 22}]$$

For voltage harmonic  $U_h$ ,  $THD_U$  is defined as follows:

$$THD_U = \sqrt{\sum_{h=2}^{h=40} \left( \frac{U_h}{U_1} \right)^2}$$

For *PV power plants* consisting of multiple *electricity-generating units*, the contributions from the individual *units i* may be summarised in accordance with the general summation law, see IEC/TR 61000-3-6 [ref. 19] and DS/EN 61000-3-11 [ref. 21] according to the following formula:

$$I_h = \sqrt[\alpha]{\sum_i I_{h,i}^\alpha}$$

Values for the exponent  $\alpha$  appear from the table below.

Harmonic order	$\alpha$ (alfa)
$h < 5$	1
$5 \leq h \leq 10$	1.4
$h > 10$	2
$h > 39$	3

Table 11 Values for the exponent  $\alpha$ .

Calculation examples can be found in 'Guidelines on the calculation of power quality parameters – TR 3.2.2' [ref. 37].

Alternatively, use the approved emission model to verify that the limit values are met.

#### 4.5.3.1 Category A2 and B PV power plants

Verify that the limit values are observed at all levels of generated active power.

#### 4.5.3.2 Category C and D PV power plants

Verify that the limit values are observed at all levels of generated active power.

Translate the sum of the individual harmonic currents  $I_h$  into harmonic voltages by multiplying the individual harmonic currents by the numerical value of the

grid impedance at the individual frequencies as stated by the *electricity supply undertaking*.

Unless otherwise stated by the *electricity supply undertaking*, use the approximate model for the frequency dependence of the grid impedance in 'Guidelines on the calculation of power quality parameters – TR 3.2.2' [ref. 37] – section: 'Approximate model for the frequency dependence of the grid impedance'.

Calculations of emission limits are described by means of examples in 'Guidelines on the calculation of power quality parameters – TR 3.2.2' [ref. 37].

## **4.6 Interharmonic distortions**

Emission of interharmonic distortions must be documented for the entire *PV power plant*.

### **4.6.1 Data basis**

The type test specifies measured mean values for interharmonic distortions in the 75 Hz to 1975 Hz frequency range for 11 levels of generated active power from 0% to 100% of the *rated power* and with a *power factor* of 1.

The measured mean values are stated as a percentage of the *rated current*  $I_n$ .

### **4.6.2 Limit values**

The *PV power plant* is not allowed to emit interharmonic distortions exceeding the limit values specified in this section.

#### **4.6.2.1 Requirements for category A2 PV power plants**

There are no requirements for interharmonic distortions for this category.

#### **4.6.2.2 Requirements for category B PV power plants**

The limit values for interharmonic distortion emissions appear from the table below which is based on RA557 [ref. 31] and scaling according to the specifications in DS/EN 61000-3-12 [ref. 22].

Voltage level	SCR	Frequency (Hz)		
		75 Hz	125 Hz	>175 Hz
$U_C \leq 1\text{kV}$	<33	0.4	0.6	$\frac{75}{f}$ *)
	$\geq 33$	0.5	0.7	$\frac{83}{f}$ *)
	$\geq 66$	0.6	0.8	$\frac{104}{f}$ *)
	$\geq 120$	0.7	1.1	$\frac{139}{f}$ *)
	$\geq 250$	1.2	1.8	$\frac{224}{f}$ *)
	$\geq 350$	1.5	2.3	$\frac{289}{f}$ *)
$U_C > 1\text{kV}$	-	0.44	0.66	$\frac{83}{f}$ *)

\*) Though not less than 0.1%.

Table 12 Limit values for interharmonic distortion emissions – B.

#### 4.6.2.3 Requirements for category C and D PV power plants

The *electricity supply undertaking* determines emission limits for interharmonic distortions from the *PV power plant* in the *Point of Connection*.

The emission limits are to ensure that the *electricity supply undertaking's* planning limits for the individual interharmonic distortions are not exceeded in the *Point of Connection*.

#### 4.6.3 Verification

##### 4.6.3.1 Category A2 PV power plants

There are no verification requirements for this category.

##### 4.6.3.2 Category B, C and D PV power plants

Verify that the *PV power plant* complies with the limit values for interharmonic distortion emissions in the same way as for harmonic distortion emissions, see section 4.5.3.2. However, the exponent  $\alpha=3$  must be used if the summation rules are used.

Alternatively, use the approved emission model to verify that the limit values are met.

#### 4.7 Distortions in the 2-9 kHz frequency range

Emission of distortions in the 2-9 kHz frequency range must be documented for the entire *PV power plant*.



#### 4.7.1 Data basis

The type test specifies measured mean values for frequency components of the current in groups of 200 Hz width from 2 kHz to 9 kHz for 11 levels of generated active power from 0% to 100% of the *rated power* and a *power factor* of 1. Measured mean values are stated as percentages of the *rated current*  $I_n$ .

#### 4.7.2 Limit values

##### 4.7.2.1 Requirements for category A2 PV power plants

There are no requirements for distortions above 2 kHz.

##### 4.7.2.2 Requirements for category B PV power plants

The emission of currents with frequencies higher than 2 kHz must not exceed 0.2% of the *rated current* in any of the frequency groups measured.

##### 4.7.2.3 Requirements for category C and D PV power plants

The *electricity supply undertaking* determines emission limits for voltages from the *PV power plant* in the *Point of Connection*.

The emission limits are to ensure that the *electricity supply undertaking's* planning limits for the individual frequency groups are not exceeded in the *Point of Connection*.

#### 4.7.3 Verification

##### 4.7.3.1 Category A2 PV power plants

There are no verification requirements for this category.

##### 4.7.3.2 Category B, C and D PV power plants

Verify that the *PV plant* complies with the limit values for distortion emissions above 2 kHz in the same way as for harmonic distortion emissions. However, the exponent  $\alpha=3$  must be used if the summation rules are used.

Alternatively, use the approved emission model to verify that the limit values are met.

## 5. Control and regulation

### 5.1 General requirements

All control functions mentioned in the following sections refer to the *Point of Connection*.

It must be possible to activate/deactivate all control functions and to set them using external signals as described in section 7.

Before the *PV power plant* can be connected to the *public electricity supply grid*, the currently activated functions and parameter settings must be agreed with the *electricity supply undertaking* within the framework laid down by the *transmission system operator*.

In order to ensure the security of supply, the *transmission system operator* must be able to activate or deactivate the specified control functions, and - by further agreement with the *plant owner* - change the current function settings via for example set points and activation commands.

All setting values for frequency parameters are determined by the *transmission system operator*.

A detailed description of the required signals, control functions and standard values for parameters etc. can be found in the document 'Guidelines on signal list – TR 3.2.2' [ref. 39].

The signs used in all figures follow the *generator convention*.

Required MW and MVar services are reduced proportionately relative to the number of *electricity-generating units* in operation in the entire *plant*.

The table below shows the minimum functionality requirements for the respective *PV power plant* sizes.

Section 7.3 lists required activation signals and related parameters.

<b>Control function</b>	<b>Category</b>	<b>A2</b>	<b>B</b>	<b>C</b>	<b>D</b>
<i>Frequency response (5.2.1)</i>		X	X	X	X
<i>Frequency control (5.2.2) *)</i>		-	-	X	X
<i>Absolute power constraint (5.2.3.1)</i>		X	X	X	X
<i>Delta power constraint (5.2.3.2)</i>		-	-	X	X
<i>Ramp rate constraint (5.2.3.3)</i>		X	X	X	X
<i>Q control (5.3.1)*</i>		X	X	X	X
<i>Power Factor control (5.3.2)*</i>		X	X	X	X
<i>Automatic Power Factor control (5.3.4) *)</i>		X	X	-	-
<i>Voltage control (5.3.3) *)</i>		-	-	X	X
<i>System protection (5.4)</i>		-	-	X	X

The bracketed numbers in the individual rows indicate the sections that describe the functions.

\*) A plant must not perform *frequency control*, *Q control*, *Power Factor control*, *automatic Power Factor control* or *voltage control* without specific agreement with the *transmission system operator*.

*Table 13 Overview of control functions required for PV power plants.*

*PV power plants* must be equipped with the control functions specified in Table 13.

The purpose of the various control functions is to ensure overall control and monitoring of the *PV power plant's* output.

The various control functions may be implemented in the individual *electricity-generating unit*, be combined into a single *plant controller*, or a combination thereof, provided there is only one communication interface as shown in Figure 7.

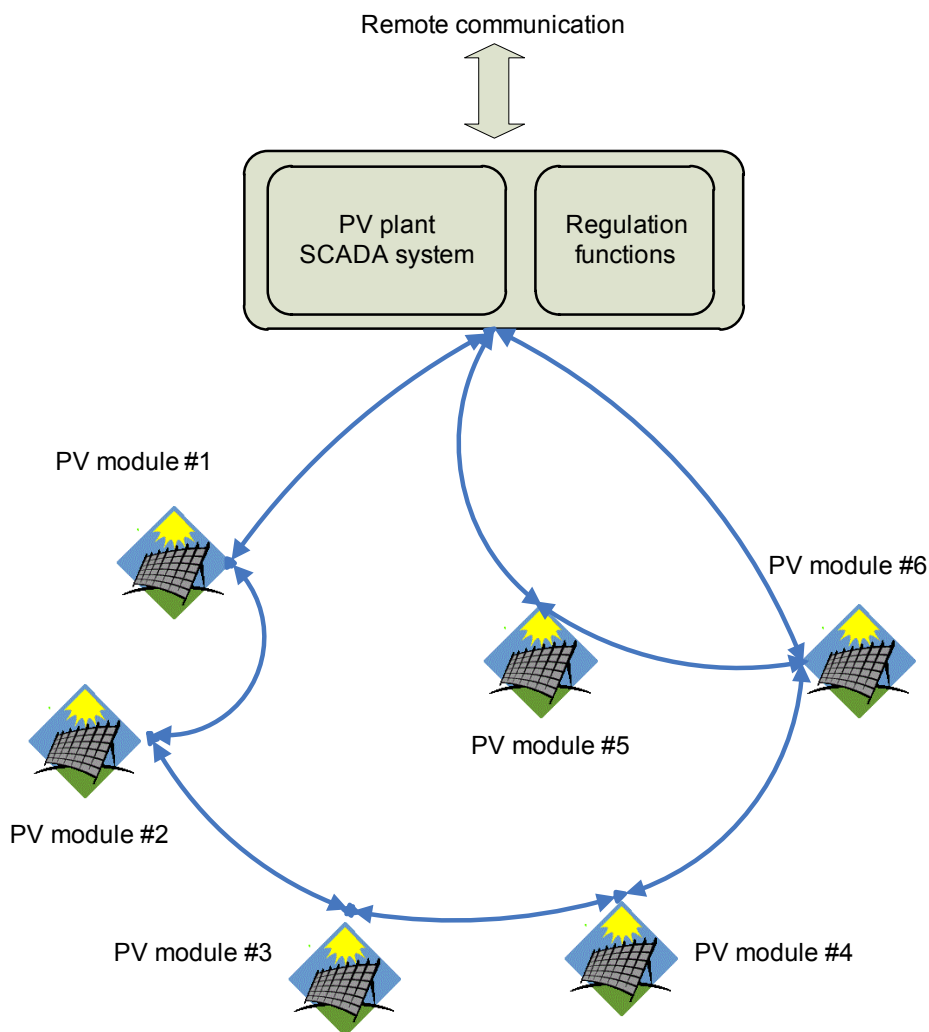

Figure 7 Drawing of a plant controller.

All set point changes must be registered with an identification of the party requesting the change.

All set point changes or orders for output changes must be time stamped with a maximum accuracy of 10 ms and must refer to UTC.

## 5.2 Active power control functions

A PV power plant must be equipped with active power control functions capable of controlling the active power supplied by a PV power plant in the *Point of Connection* using activation orders with set points. It must be possible to indicate set points for active power with a 1 kW resolution or better.

Current parameter settings for activated active power control functions are determined by the *electricity supply undertaking* in collaboration with the *transmission system operator* before commissioning.

In addition to fulfilling the general requirements in section 5.1, active power control functions must comply with the requirements outlined in the following sections.

### 5.2.1 Frequency response

In the event of frequency deviations in the *public electricity supply grid*, the *PV power plant* must contribute to grid stability by automatically reducing active power at grid frequencies above  $f_R$ . This is referred to as *frequency response*.

Frequency measurements must be carried out with an accuracy of  $\pm 10$  mHz or higher and with a precision with a standard deviation ( $1 \sigma$ ) of  $\pm 5$  mHz or lower.

It must be possible to set the *frequency response* function for the frequency points shown in Figure 8.

It must be possible to set the frequency  $f_R$  to any value in the 50.00-52.00<sup>1</sup> Hz range with an accuracy of 10 mHz or higher. The standard  $f_R$  value is 50.20 Hz. The  $f_R$  setting value is determined by the *transmission system operator*.

It must be possible to set the *droop* for the downward regulation to any value in the range 2-12% of  $P_n$  and this must be effected with an accuracy of  $\pm 10\%$  of  $P_n$ . The standard value for droop is 4% of  $P_n$ . In this context, *droop* is the change in active power as a function of the grid frequency. *Droop* is stated as a percentage of the *plant's* nominal output.

The *frequency response* control must start no later than two seconds after a frequency change is detected and must be completed within 15 seconds.

The *electricity supply undertaking* in whose grid the *plant* is connected can coordinate initiation of the *frequency response* in relation to the trip time of island operation mode detection and thereby ensure optimal island operation mode detection functionality.

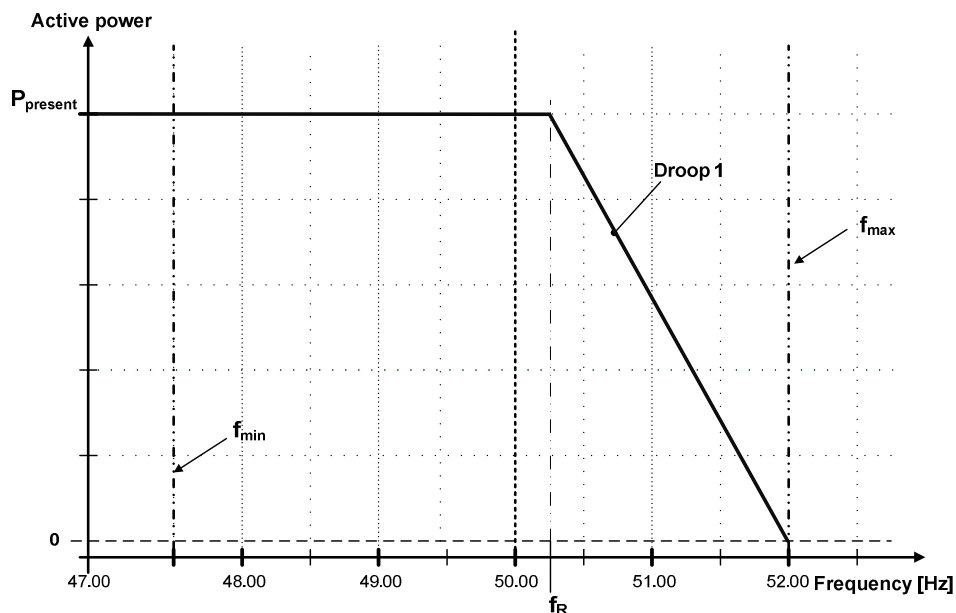

Figure 8 Frequency response for a PV power plant.

<sup>1</sup> The function is deactivated if  $f_R$  is set to 52 Hz.

### 5.2.2 Frequency control

In case of frequency deviations in the *public electricity supply grid*, the *PV power plant* must be able to provide *frequency control* to stabilise the grid frequency (50.00 Hz).

The purpose of the *frequency control* function is to control active power at grid frequencies above  $f_R$  as shown in Figure 9.

The metering accuracy for the grid frequency must be  $\pm 10$  mHz or better.

The accuracy of the control performed and of the set point must not deviate by more than  $\pm 5\%$  of the set point value or by  $\pm 0.5\%$  of the *rated power*, depending on which yields the highest tolerance.

It must be possible to set the *frequency control* function for all frequency points shown in Figure 9, just as it must be possible to set the frequencies  $f_{\min}$ ,  $f_{\max}$  and  $f_1$  to  $f_7$  to any value in the 47.00 Hz to 52.00 Hz range with an accuracy of 10 mHz.

The purpose of frequency points  $f_1$  to  $f_4$  is to be able to produce different *frequency response* curves in line with the delivery requirements for the critical power frequency ancillary service, see TR 5.9.1 [ref. 11].

The *droop* required to perform control between the various frequency points is illustrated in Figure 9 and specified in the signal list in section 7.

In this context, *droop* is the change in active power as a function of the grid frequency. *Droop* is stated as a percentage of the *plant's* nominal output.

In case of grid frequencies above  $f_5$ , upward regulation of the *PV power plant* must not be commenced until the grid frequency is lower than  $f_7$ .

$P_{\Delta}$  is the power by which the available active power is reduced in order to provide frequency stabilisation (upward regulation) in the case of falling grid frequency.

Figure 9 illustrates the location of the various parameters and limits for the *frequency control* function.

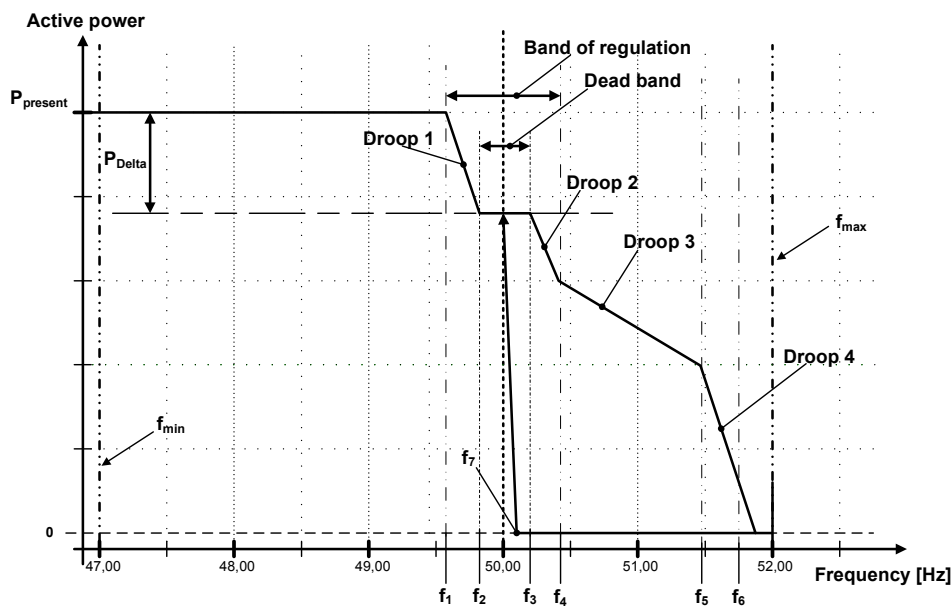

Figure 9 Frequency control curve for a PV power plant.

It must be possible to activate the *frequency control* function in the  $f_{\min}$  to  $f_{\max}$  range.

*Frequency control* using a new parameter set must be possible no later than 10 seconds from receipt of the order to change the parameter.

### 5.2.3 Constraint functions

A *PV power plant* must be equipped with constraint functions, ie supplementary active power control functions.

The constraint functions are used to avoid instability or overloading of the *public electricity supply grid* in connection with switching in the *public electricity supply grid*, in fault situations or the like.

The required constraint functions are specified in the sections below.

#### 5.2.3.1 Absolute power constraint

An *absolute power constraint* is used to limit active power from a *PV power plant* to a set point-defined maximum power limit in the *Point of Connection*.

An *absolute power constraint* is mainly used to protect the *public electricity supply grid* against overload in critical situations.

Control using a new parameter for the *absolute power constraint* must be commenced within two seconds and completed no later than 10 seconds after receipt of an order to change the parameter.

#### 5.2.3.2 Delta power constraint (spinning reserve)

A *delta power constraint* is used to limit the active power from a *PV power plant* to a desired constant value in proportion to the possible active power.

A *delta power constraint* is often used to establish a regulating reserve for upward regulation in connection with the delivery of an ancillary service (*frequency control*).

Control using a new parameter for the *delta power constraint* must be commenced within two seconds and completed no later than 10 seconds after receipt of an order to change the parameter.

### 5.2.3.3 Ramp rate constraint

*Ramp rate constraint* is used to limit the maximum speed by which the active power can be changed in the event of changes in power or in the set points for a *PV power plant*.

*Ramp rate constraint* is normally used for reasons of system operation to prevent the changes in active power from adversely impacting the stability of the *public electricity supply grid*.

Control using a new parameter for the active power *ramp rate constraint* must be commenced within two seconds and completed no later than 10 seconds after receipt of an order to change the parameter.

The maximum standard value for the *ramp rate constraint* is 100 kW/s.

Figure 10 shows an overview of the active power constraint functions.

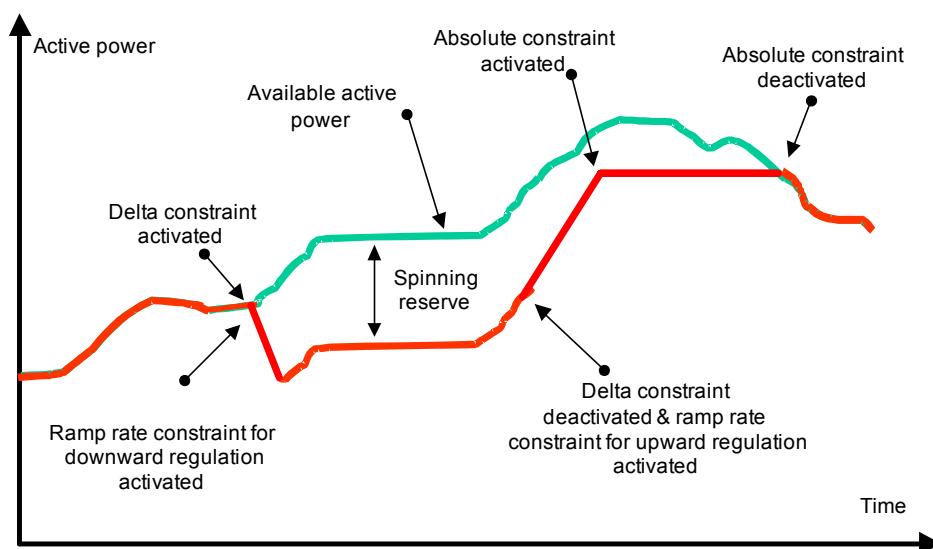

Figure 10 Drawing of constraint functions for active power.

## 5.3 Reactive power and voltage control functions

A *PV power plant* must be equipped with reactive power and voltage control functions capable of controlling the reactive power supplied by a *PV power plant* in the *Point of Connection*, and with a control function capable of controlling the voltage in the *voltage reference point* via activation orders containing set points for the specified parameters.



The control functions for the supply of a specific reactive power, *Power Factor* and *voltage control* are mutually exclusive, which means that only one of the three functions can be activated at a time.

Before commissioning, current parameter settings for reactive power and voltage control functions must be determined by the *electricity supply undertaking* in collaboration with the *transmission system operator*.

In addition to fulfilling the general requirements in section 5.1, the reactive power control, *Power Factor control* and *voltage control* functions must comply with the requirements in the following sections.

### 5.3.1 Q control

The *Q control* function controls the reactive power independently of the active power in the *Point of Connection*.

This control function is shown as a horizontal line in Figure 11.

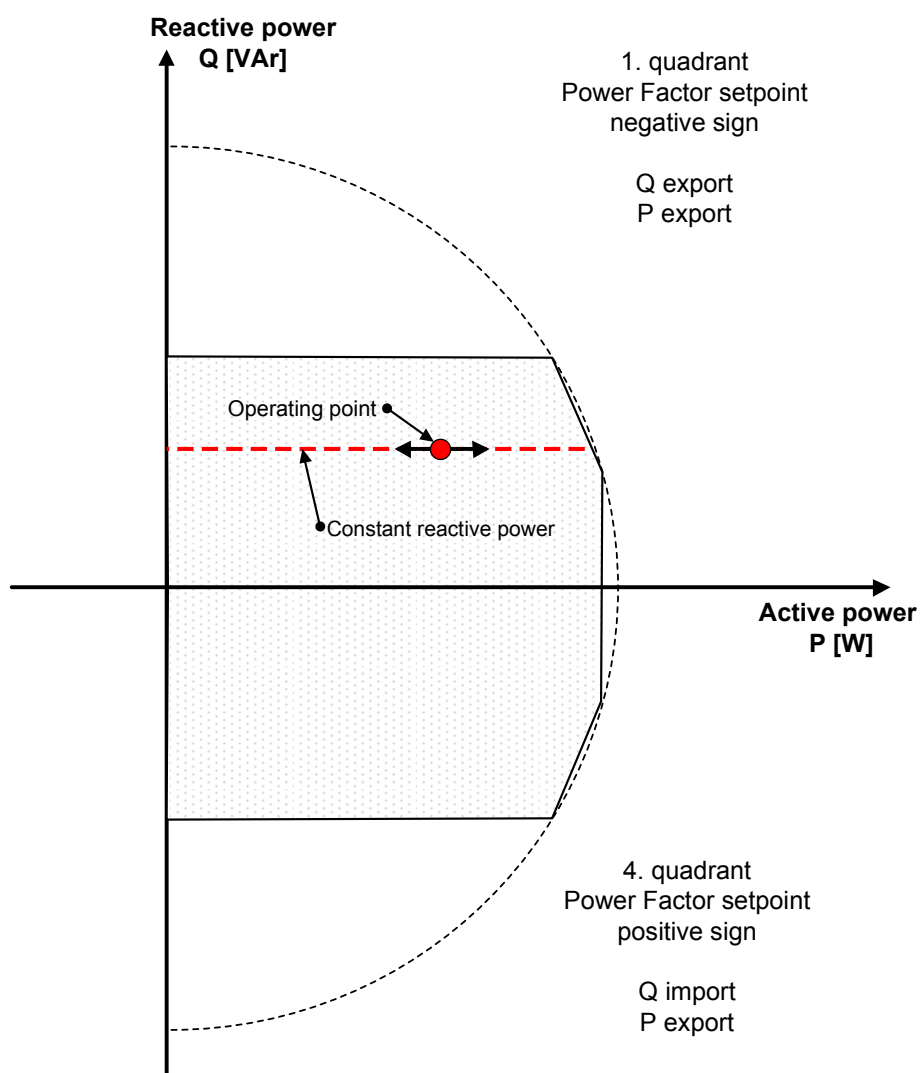

Figure 11 Reactive power control functions for a PV power plant.

Any change to the Q control set point must be commenced within two seconds and completed no later than 10 seconds after receipt of an order to change the set point.

The *PV power plant* must be able to receive a Q set point with an accuracy of 0.1 kVAr.

### 5.3.2 Power factor control

The *power factor control* function controls reactive power proportionately to the active power in the *Point of Connection*, which is shown by a line with a constant gradient in Figure 12.

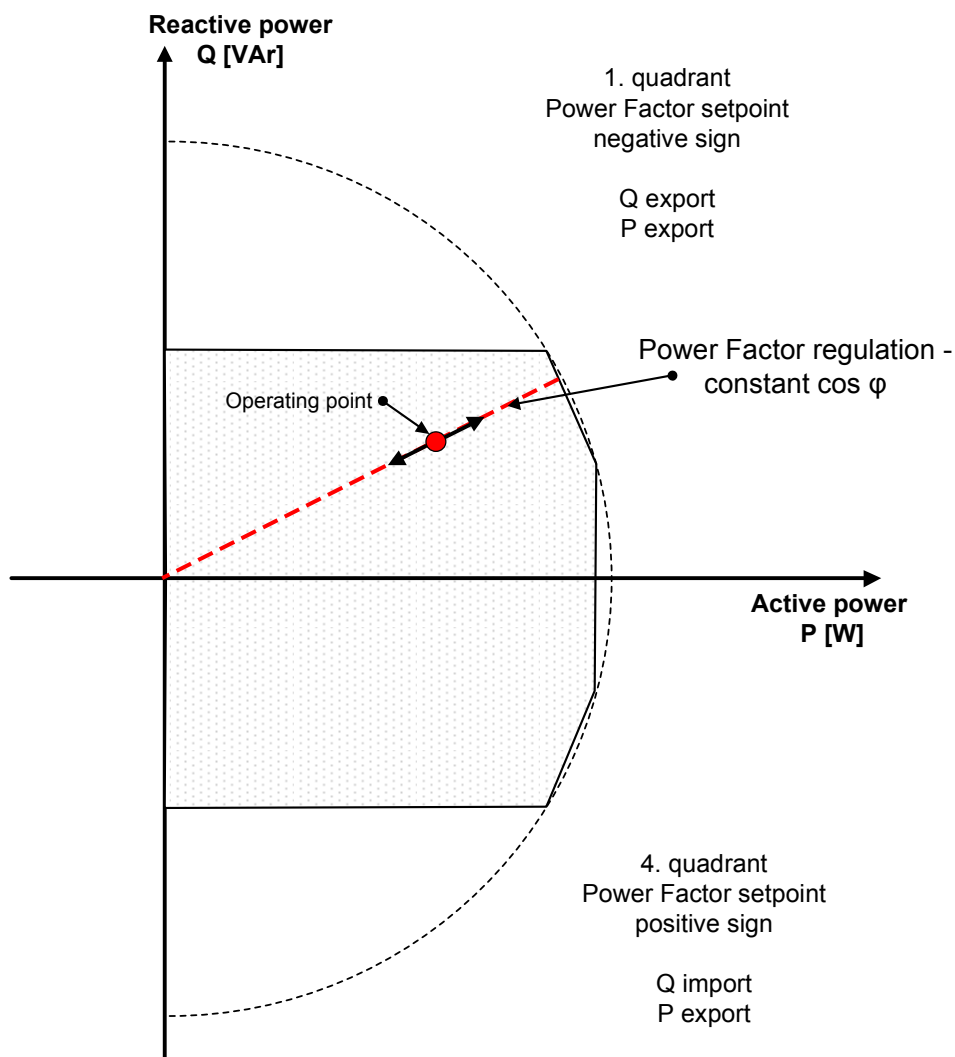

Figure 12 Power Factor control (PF) for a PV power plant.

The *PV power plant* must be able to receive a *Power Factor* set point with a resolution of 0.01.

Any change to the *Power factor* set point must be commenced within two seconds and completed no later than 10 seconds after receipt of an order to change the set point.

The accuracy of the control performed and of the set point may not deviate by more than  $\pm 2\%$  of the set point value or by  $\pm 0.5\%$  of the *rated power*, depending on which yields the highest tolerance.

### 5.3.3 Voltage control

The *voltage control* function stabilises the voltage in the *voltage reference point*. *Voltage control* must have a setting range within minimum to maximum voltage as stated in Table 1, with an accuracy of 0.5% or better of the *nominal voltage*.

Any change to the voltage set point must be commenced within two seconds and completed no later than 10 seconds after receipt of an order to change the set point.

The accuracy of the control performed and of the set point may not deviate by more than  $\pm 2\%$  of the set point value or by  $\pm 0.5\%$  of the *rated voltage*, depending on which yields the highest tolerance.

The individual *PV power plant* must be capable of performing the control within its dynamic range and voltage limit with the *droop* configured.

A drawing of the concept in a *voltage control* is shown in Figure 13.

The *voltage control* reference point is the *voltage reference point*.

When the *voltage control* has reached the *PV power plant's* dynamic design limits, the control function must await a possible overall control from the tap changer or other *voltage control* functions.

Overall voltage coordination is managed by the *electricity supply undertaking* in collaboration with the *transmission system operator*.

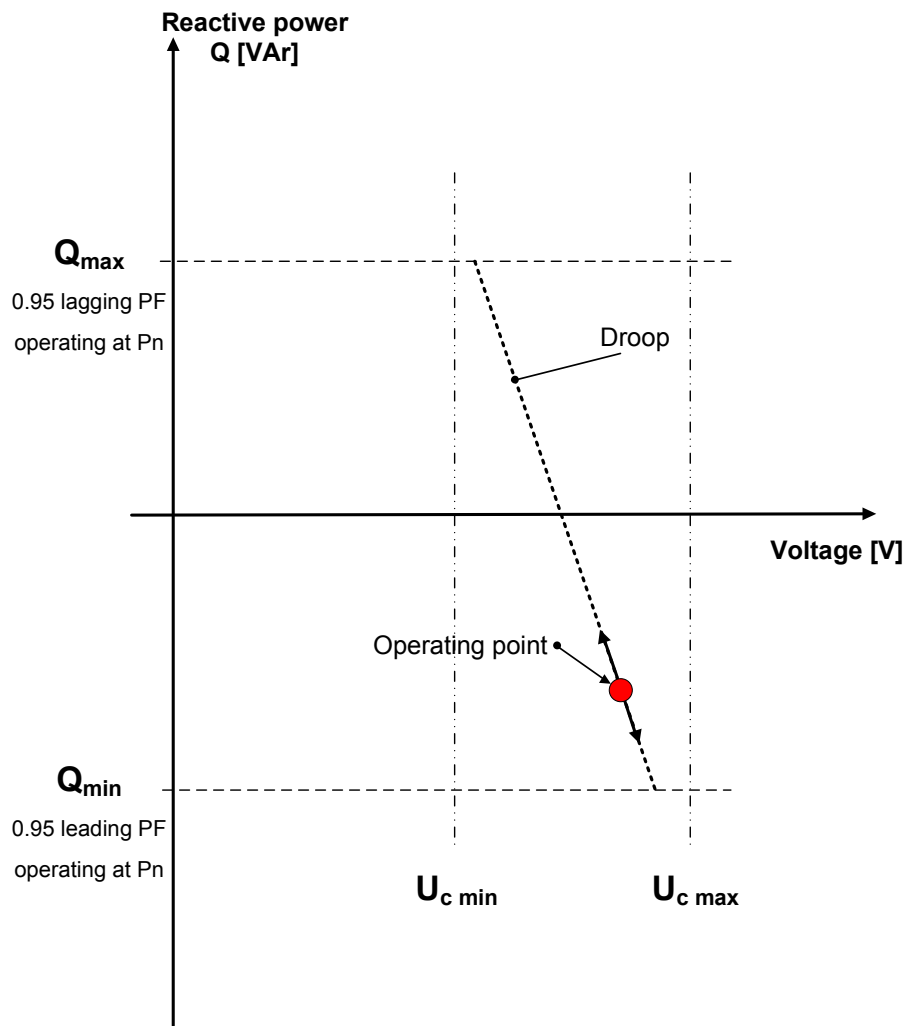

Figure 13 Voltage control for a PV power plant.

### 5.3.4 Automatic Power Factor control

The automatic *Power Factor control* function automatically activates/deactivates the *Power Factor control* at defined voltage levels in the *voltage reference point*. The principle of the automatic *Power Factor control* is illustrated in Figure 14.

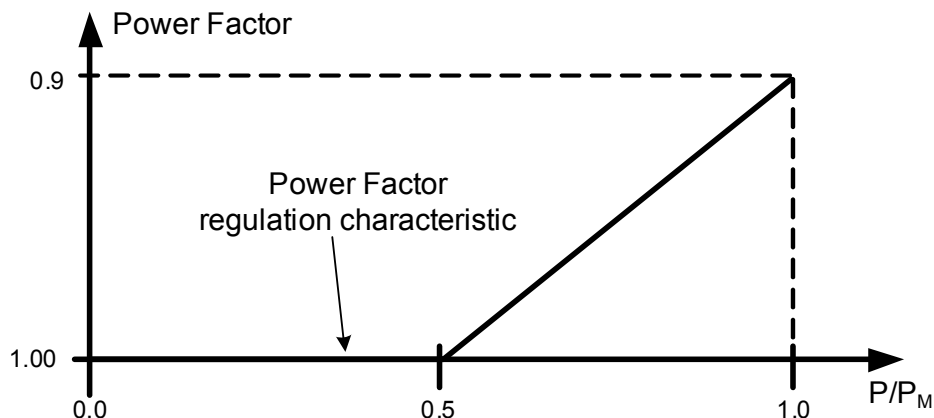

Figure 14 Automatic Power Factor control (PF) for a PV power plant.

The default setting for the *automatic Power Factor control* (PF) is given by the following three support points with linear interpolation between them:

- 1:  $P/P_M = 0.0$ ,  $PF = 1.00$
- 2:  $P/P_M = 0.5$ ,  $PF = 1.00$
- 3:  $P/P_M = 1.0$ ,  $PF = 0.90$

The activation level for the function is normally 105% of the *nominal voltage*, and the deactivation level is normally 100% of the *nominal voltage*. The activation/deactivation level must be adjustable via set points.

As a starting point, the function must be deactivated and must be activated only by agreement with the *electricity supply undertaking*.

## 5.4 System protection

A *PV power plant* must be equipped with system protection – a control function which must be capable of very quickly regulating the active power supplied by a *PV power plant* to one or more predefined set points based on a downward regulation order. The set points are determined by the *electricity supply undertaking* upon commissioning.

The *PV power plant* must have at least five different configurable regulation step options.

The following regulation steps are recommended as default values:

1. Up to 70% of *rated power*
2. Up to 50% of *rated power*
3. Up to 40% of *rated power*
4. Up to 10% of *rated power*
5. Up to 0% of *rated power*, ie the *plant* is shut down, but not disconnected from the grid.

Regulation must be commenced within one second and completed no later than 10 seconds after receipt of a downward/upward regulation order.

The accuracy of the control performed and of the set point may not deviate by more than  $\pm 2\%$  of the set point value or by  $\pm 0.5\%$  of the *rated power*, depending on which yields the highest tolerance.

### 5.5 Order of priority for control functions

The individual control functions of a *PV power plant* must be ranked in order of priority. A priority 1 control function takes precedence over a priority 2 control function and so forth.

The recommended order of priority is as follows:

1. Protective functions, see section 6
2. System protection, see section 5.4
3. *Frequency control*, see section 5.2.2
4. Constraint functions, see section 5.2.3.

### 5.6 Active power control requirements

As a minimum, *PV power plants* must be equipped with the control functions specified in Table 14.

It must be possible to indicate set points for active power with a resolution of at least 0.1 kW or better.

The table below specifies the minimum requirements for control functionality for active power in the four *plant categories*.

Category Control function	A2	B	C	D
<i>Frequency response</i> (5.2.1) *)	X	X	X	X
<i>Frequency control</i> (5.2.2) *)	-	-	X	X
<i>Absolute power constraint</i> (5.2.3.1)	X	X	X	X
<i>Delta power constraint</i> (5.2.3.2)	-	-	X	X
<i>Ramp rate constraint</i> (5.2.3.3)	X	X	X	X
System protection (5.4)	-	-	X	X

The bracketed numbers in the individual rows indicate the sections that describe in which the function.

\*) By default, a *PV power plant* must be configured with the *frequency response* function activated. Other methods of *frequency control* must be agreed with the *transmission system operator*.

Table 14 Active power control functions.

#### 5.6.1 Category A2 and B PV power plants

In addition to fulfilling the general requirements in section 5.1 and the *normal production* requirements in section 3.2, category A2 and B *PV power plants* must as a minimum be equipped with the control functions specified in 5.

A *PV power plant* in these categories must be prepared for receiving an external signal for production 'Stop' and an external signal 'Released for start', which allows production to start when the normal operating conditions specified in section 3.2 are met.

The signals must be accessible via a terminal strip or commands in accordance with the specifications in section 7.

### 5.6.2 Category C and D PV power plants

In addition to fulfilling the general requirements in section 5.1 and the *normal production* requirements in section 3.2, category C and D *PV power plants* must as a minimum be equipped with the control functions specified in section 5.

The signals must be accessible via commands in accordance with the specifications in section 7.

### 5.7 Reactive power control requirements

As a minimum, *PV power plants* must be equipped with the reactive power control functions specified in Table 15.

The *PV power plant* must be designed in such a way that the operating point always can be ordered to lie within the hatched area shown in the relevant figures for the different *plant categories*.

The table below shows the minimum functionality requirements for reactive power control in the different *plant categories*.

Control function \ Category	A2	B	C	D
<i>Q control</i> (5.3.1)*	X	X	X	X
<i>Power Factor control</i> (5.3.2)*	X	X	X	X
<i>Voltage control</i> (5.3.3) *)	-	-	X	X
<i>Automatic Power Factor control</i> (5.3.4) *)	X	X	-	-

The bracketed numbers in the individual rows indicate the sections that describe the function.

\*) By default, a *plant* must be configured with *Q control* and with a set point of 0 VAR. Other methods of reactive power control must be agreed with the *electricity supply undertaking*.

Table 15 Reactive power control functions.

#### 5.7.1 Category A2 PV power plants

In addition to fulfilling the general requirements in section 5.1 and the *normal production* requirements in section 3.2, *PV power plants* in this category must as a minimum be equipped with the control functions specified in Table 15. The operating point must as a minimum lie within the *Power Factor* interval of 0.90 to 1.00 at active power production above 20% of the *rated power* and must, by default, follow a *Power Factor* of 1.00, unless otherwise agreed.

### 5.7.2 Category B PV power plants

In addition to fulfilling the general requirements in section 5.1 and the *normal production* requirements in section 3.2, *PV power plants* in this category must as a minimum be equipped with the control functions specified in Table 15. Unless otherwise agreed, the operating point must, by default, follow a *power factor* of 1.00.

In addition to fulfilling the general requirements in section 5.1 and the normal production requirements in section 3.2, it must at any time be possible to order the PV power plant's operating point to lie within the hatched area shown in Figure 15. There are no precision and accuracy requirements for the *Power factor*, when the apparent power is less than 20% of the nominal output.

When the *PV power plant* is disconnected or not producing any active power, no compensation is required for the reactive power from the *plant infrastructure*.



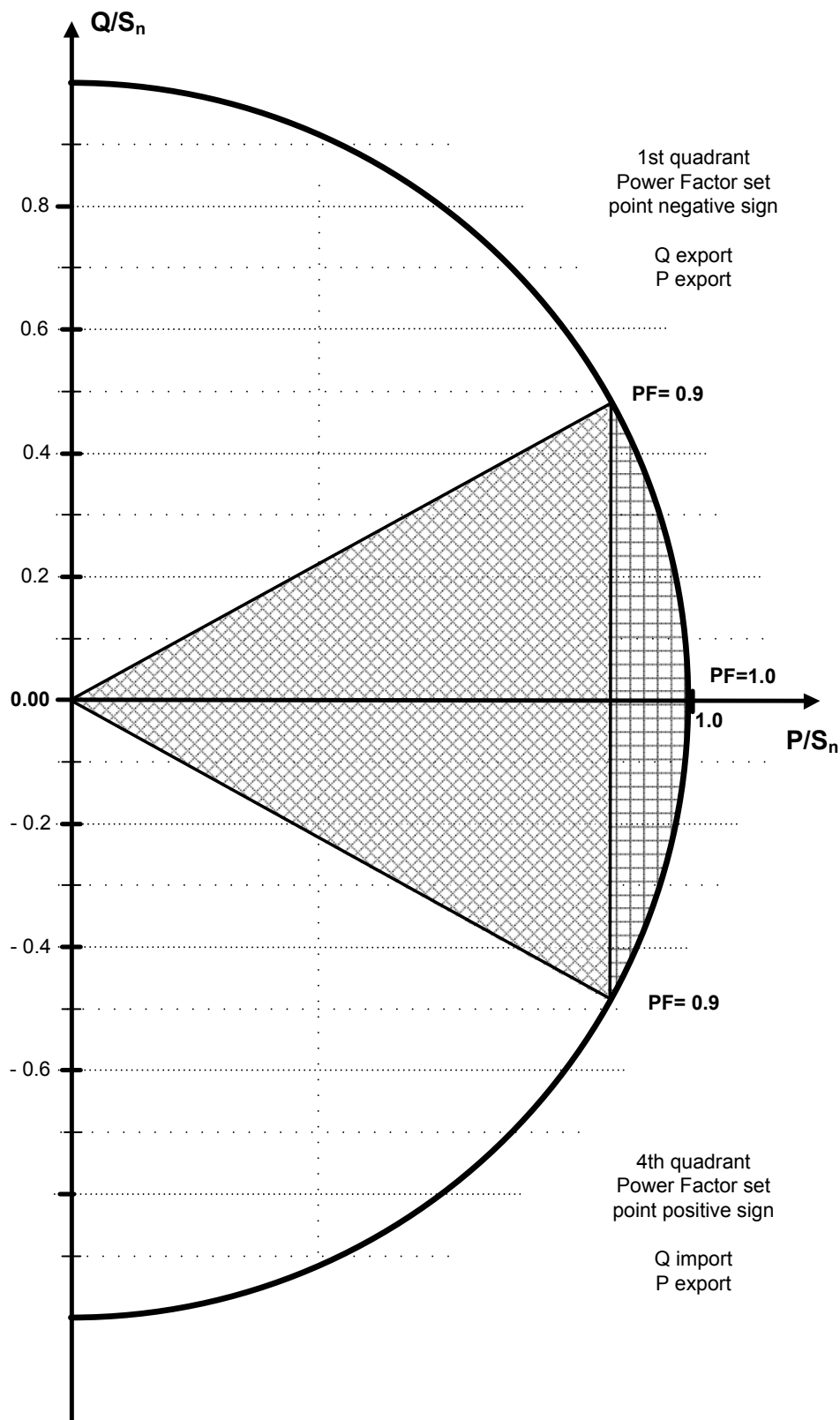

Figure 15 Requirements for the delivery of reactive power as a function of  $P/S_n$  for category B PV power plants.

It is accepted that the ability to deliver reactive compensation in the chequered area may depend on the *plant* technology.

It must be possible to deliver the reactive power in the voltage range indicated in the figure below.

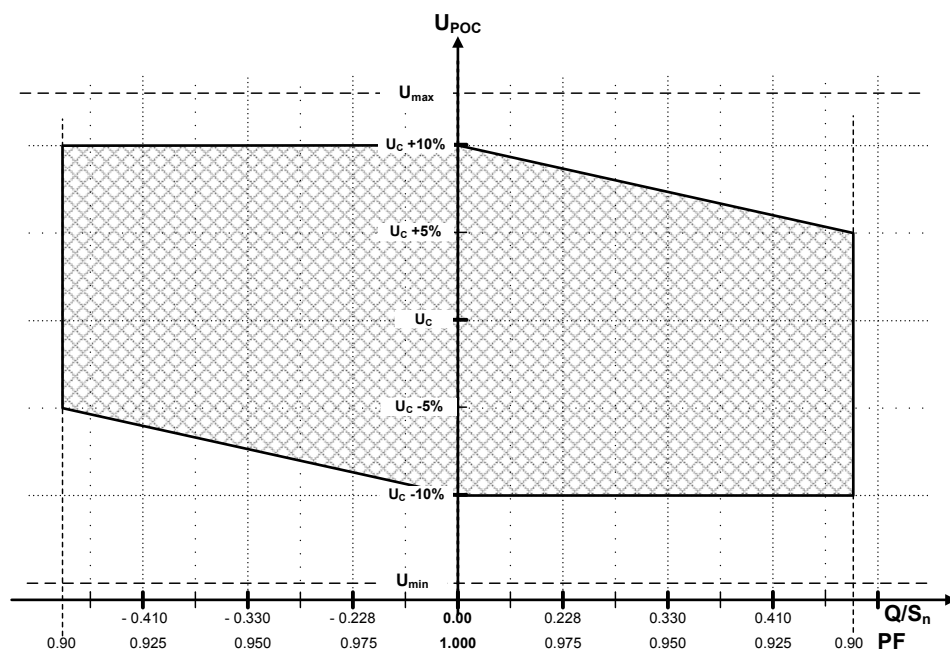

Figure 16 Requirements for the delivery of reactive power as a function of the voltage in the POC for category B PV power plants.

### 5.7.3 Category C PV power plants

In addition to fulfilling the general requirements in section 5.1 and the *normal production* requirements in section 3.2, *PV power plants* in this category must as a minimum be equipped with the control functions specified in Table 15.

The *PV power plant* must be designed in such a way that the operating point can at any time be ordered to lie within the hatched area shown in Figure 17.

Control method and settings must be agreed upon with the *electricity supply undertaking* within the framework laid down by the *transmission system operator*.

The *plant owner* must compensate for the *plant infrastructure's* reactive power in situations where the *PV power plant* is disconnected or is not generating active power.

Compensation may take place in the electricity system by agreement with the *electricity supply undertaking*.

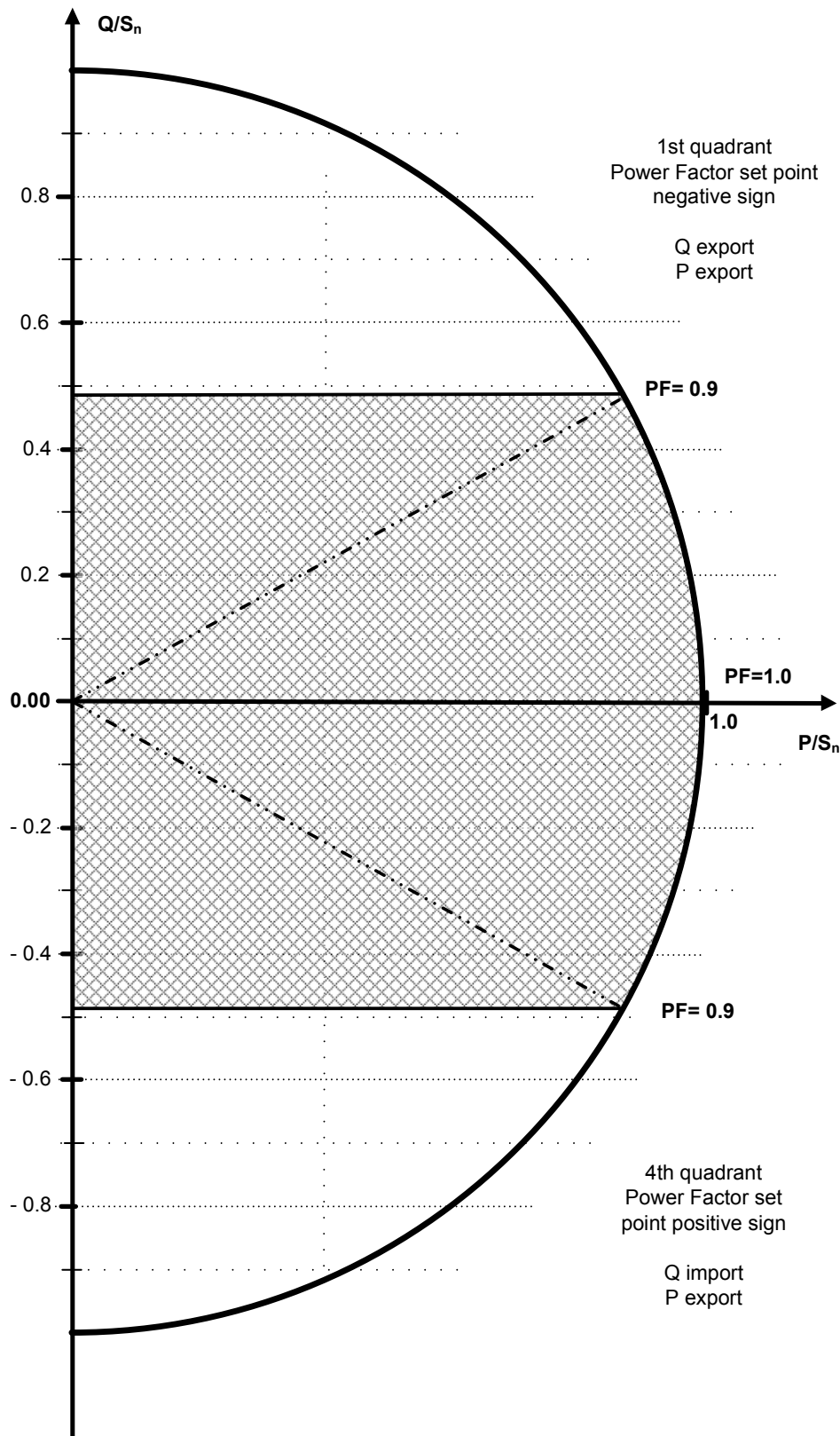

Figure 17 Requirements for the delivery of reactive power as a function of  $P/S_n$  for category C PV power plants.

It must be possible to deliver the reactive power in the voltage range as indicated in the figure below.

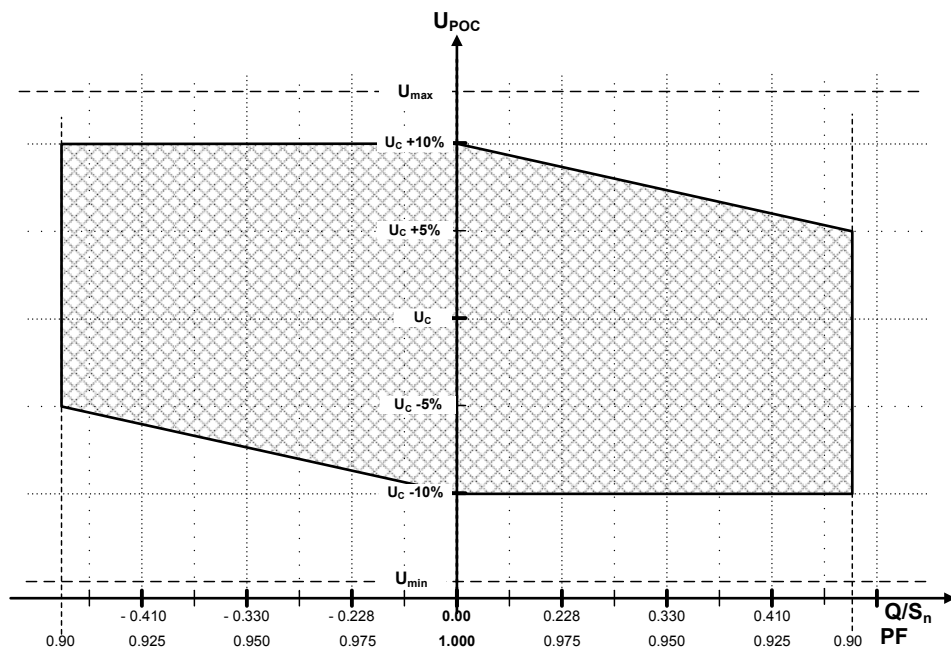

Figure 18 Requirements for the delivery of reactive power as a function of voltage in the POC for category C PV power plants.

### 5.7.4 Category D PV power plants

In addition to fulfilling the general requirements in section 5.1 and the *normal production* requirements in section 3.2, *PV power plants* in this category must as a minimum be equipped with the control functions specified in Table 15.

The *PV power plant* must be designed in such a way that the operating point can lie anywhere within the hatched area, see Figure 19.

Control method and settings must be agreed upon with the *electricity supply undertaking* within the framework laid down by the *transmission system operator*.

The *plant owner* must compensate for the *plant infrastructure's* reactive power in situations where the *PV power plant* is disconnected or is not generating active power.

Compensation may take place in the electricity system by agreement with the *electricity supply undertaking*.

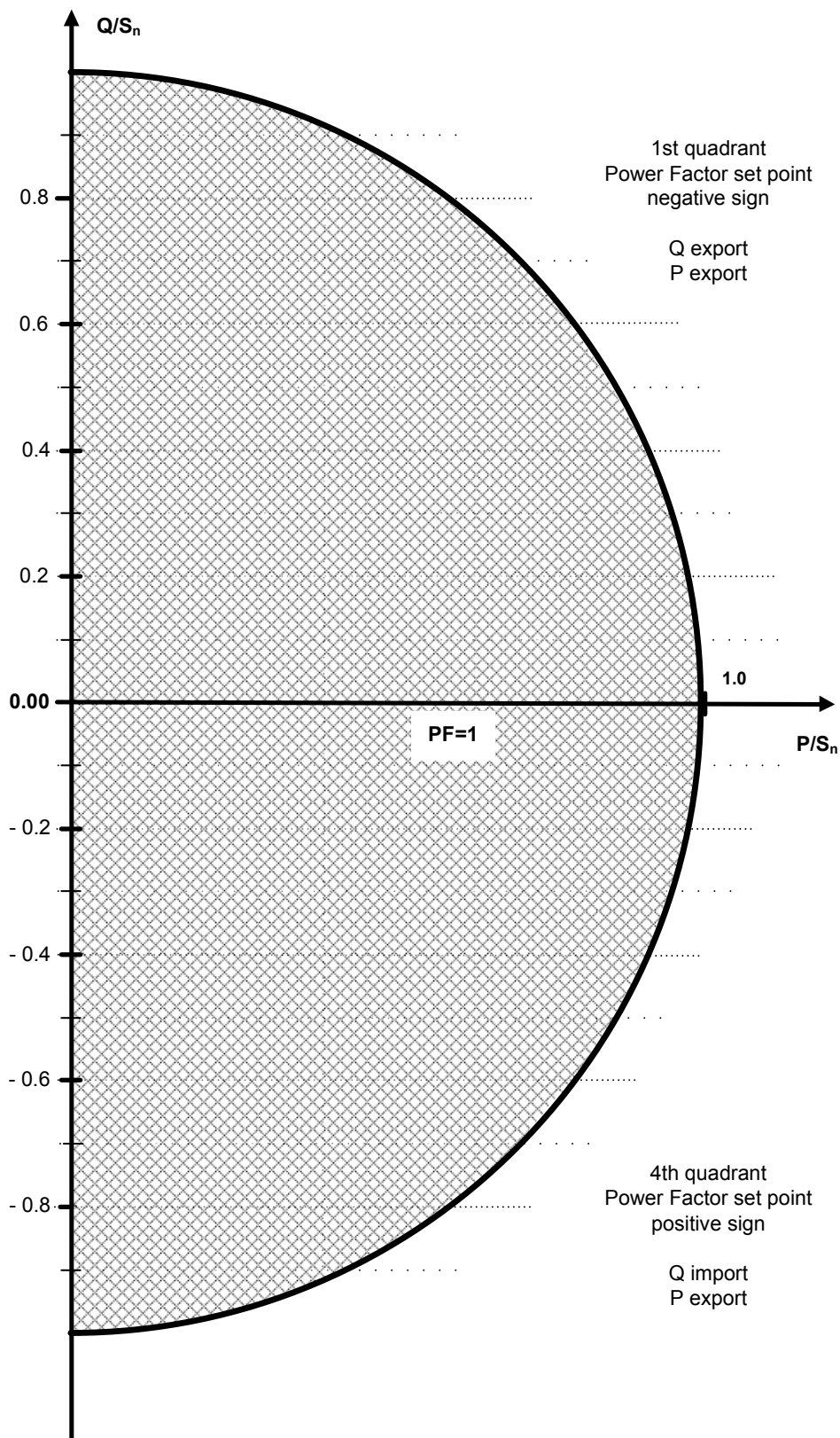

Figure 19 Requirements for the delivery of reactive power as a function of  $P/S_n$  for category D PV power plants.

It must be possible to deliver the reactive power in the voltage range as indicated in the figure below.

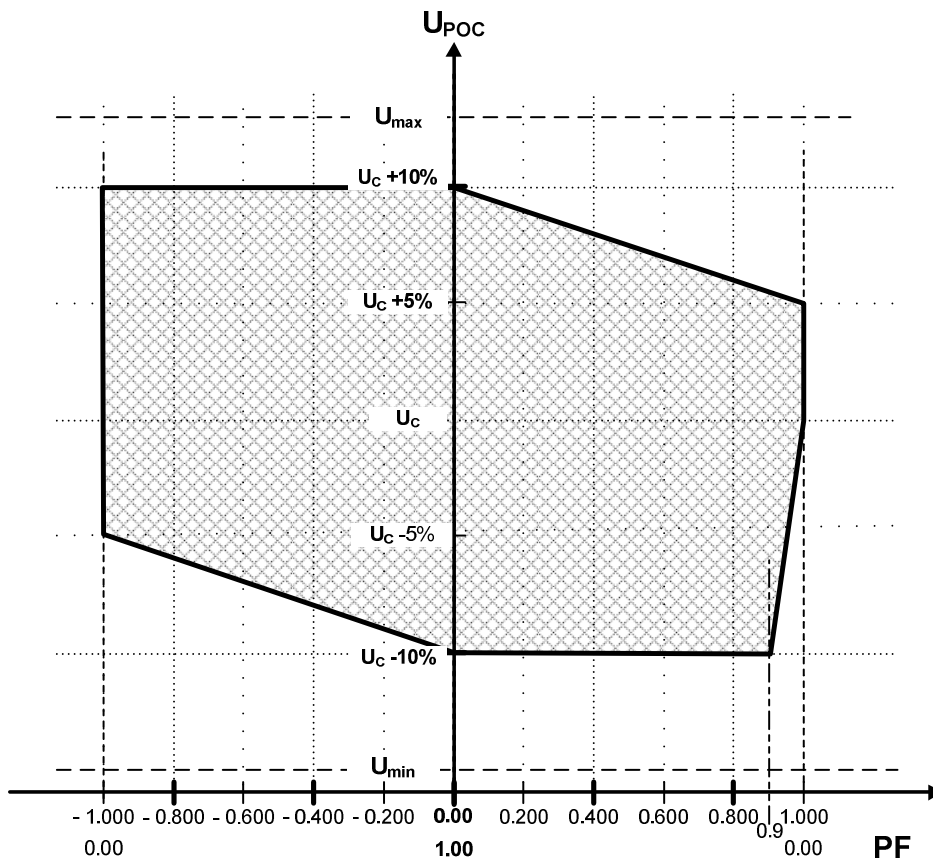

Figure 20 Requirements for the delivery of reactive power as a function of the voltage in the POC for category D PV power plants.

## 6. Protection

### 6.1 General

The purpose of the PV power plant's protective functions is to protect the *PV power plant* and to ensure a stable *public electricity supply grid*.

The *plant owner* is responsible for ensuring that the *plant* is dimensioned and equipped with the necessary protective functions so that the *PV power plant*:

- is protected against damage due to faults and incidents in the *public electricity supply grid*
- protects the *public electricity supply grid* to the widest possible extent against unwanted impacts from the *plant*.

The *electricity supply undertaking* or the *transmission system operator* is entitled to demand that the setting values for protective functions be changed following commissioning if this is found to be of importance to the operation of the *public electricity supply grid*.

However, such change must not result in the *plant* being exposed to impacts outside of the design requirements, as specified in section 3, from the *public electricity supply grid*.

After a *PV power plant* has been disconnected due to a fault in the *public electricity supply grid*, the *PV power plant* must be automatically reconnected no earlier than three minutes after the voltage and the frequency are once again within the normal operating conditions stated in section 3.2.

A *PV power plant* which was disconnected by an external signal prior to a fault occurring in the *public electricity supply grid* must not be reconnected until the external signal has been eliminated, and voltage and frequency are once again within the normal operating conditions stated in section 3.2.

At the *plant owner's* request, the *electricity supply undertaking* must state the highest and lowest short circuit current that can be expected in the *Point of Connection* as well as any other information about the *public electricity supply grid* that are necessary to determine the *PV power plant's* protective functions.

### 6.2 Central protection

For category B, C and D *plants*, a joint central protection unit may be required in the *Point of Connection in Installation (PCI)* for the *electricity-generating unit* if the inverter's settings cannot be documented or do not meet the requirements in section 6.3.

The *electricity supply undertaking* decides whether there must be a central protection unit in front of the *electricity-generating unit* and its configured settings.

Consumption may not be connected between the *electricity-generating unit* and the *Point of Connection* if the *electricity-generating unit* is not connected to the installation, see section 1.2.29.

The figures below illustrate the possible configurations with and without central protection for various *plants*.

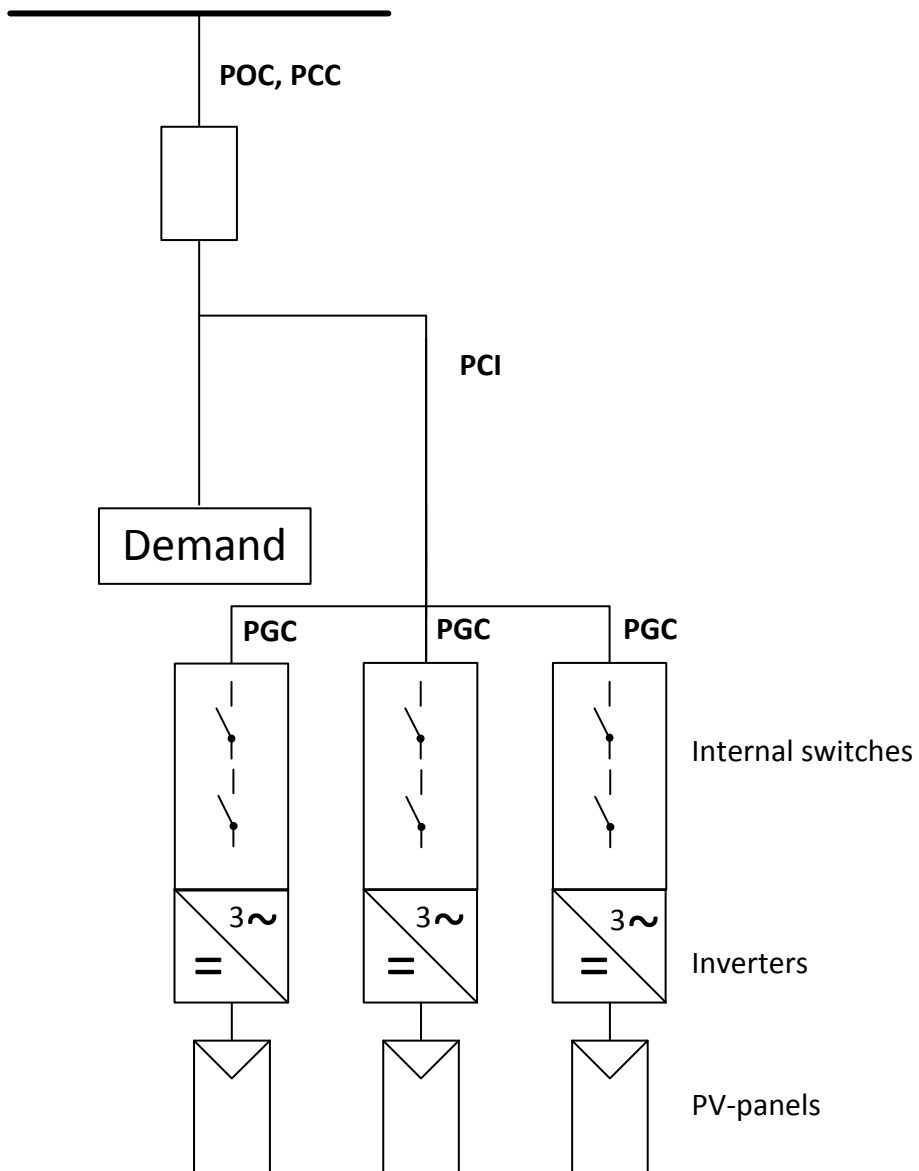

Figure 21 Overview of plants with integrated grid protection in the inverters.



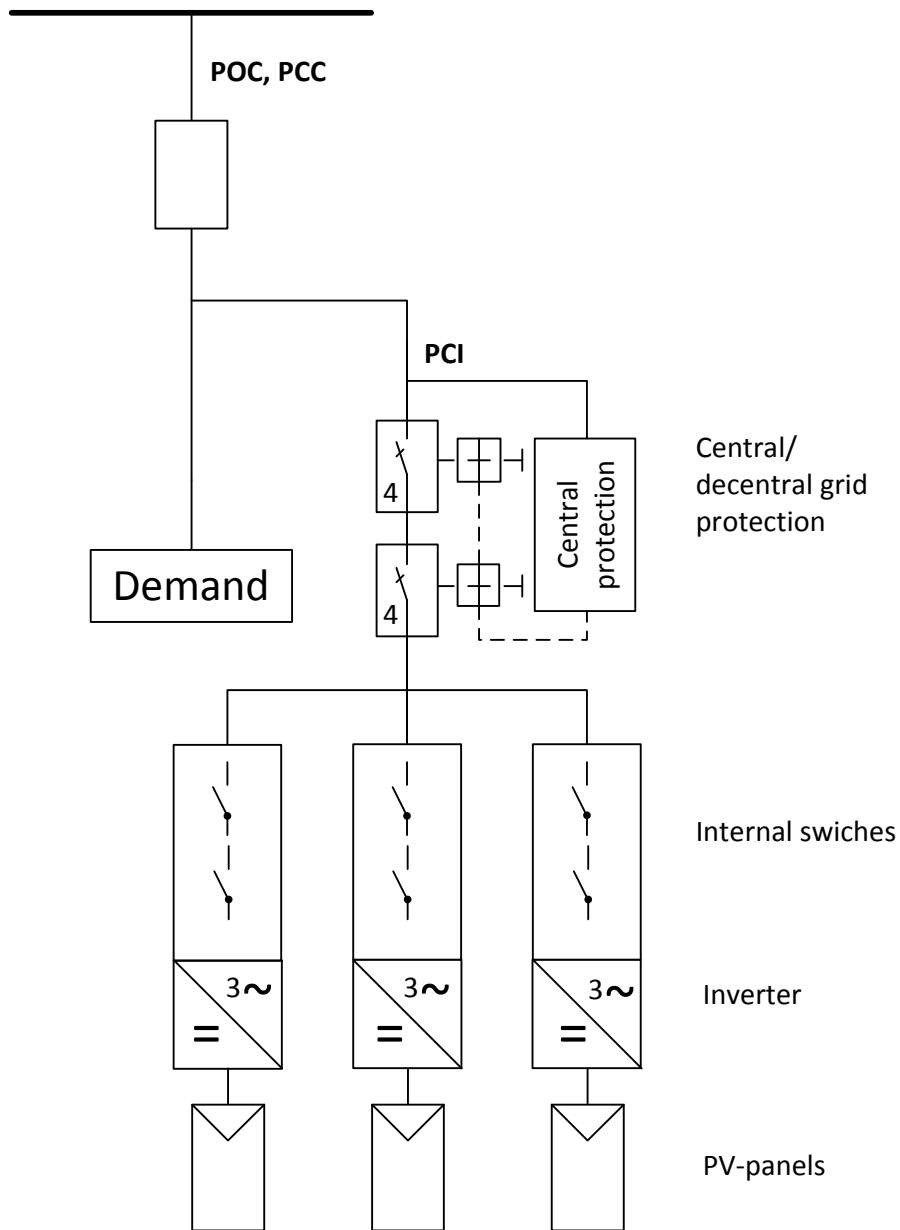

Figure 22 Overview of plants with central grid protection.

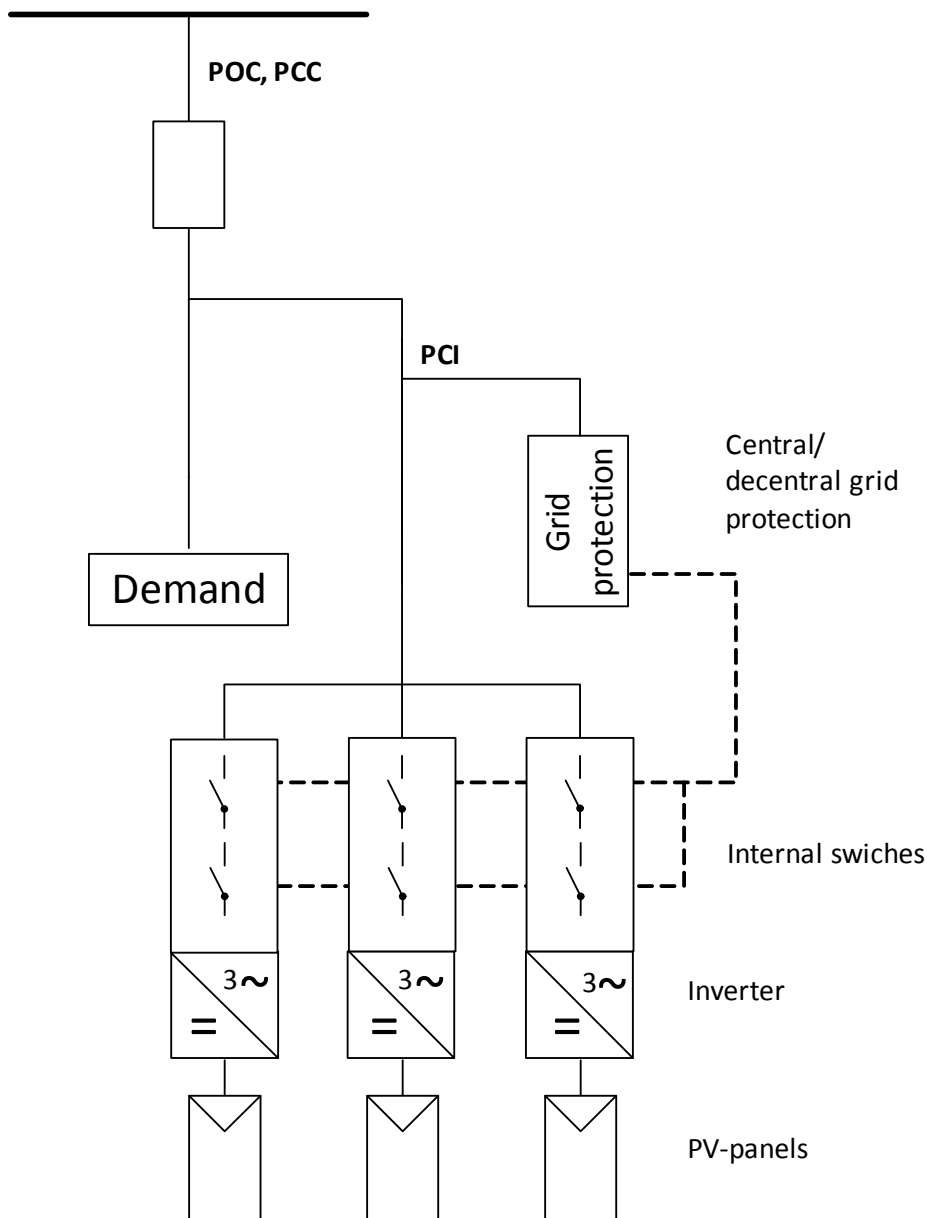

Figure 23 Overview of plants with inverters connected to local grid protection.

### 6.3 Protective setting requirements

The *PV power plant's* protective functions and associated settings must be as specified in the following subsections. Settings that deviate from the required setting values in the event of, for example, problems with local overvoltages may only be used with the *electricity supply undertaking's* permission.

All settings are stated as root-mean-square (RMS) values.

The *PV power plant* must be disconnected if a measuring signal deviates more from its nominal value than the setting.

The trip time stated is the measuring period during which the trip condition must constantly be fulfilled in order for the protective function to release a trip signal.

The use of vector jump relays as protection against island operation/loss of mains is not allowed.

It is assumed that the *nominal voltage of the plant* is determined on the low-voltage side of the *plant* transformer.

For three-winding transformers, it is the *nominal voltage* for the low-voltage winding to which the *electricity-generating unit* is connected.

If the voltage is measured on the high-voltage side, the setting value must be determined by converting the *nominal voltage* on the low-voltage side to the high-voltage side of the *plant* transformer.

Voltage must be measured for the phases applied as line-to-line voltage.

Recording of frequency must take place simultaneously on the phases used.

Alternatively, if the measuring point is located on the low-voltage side of the *plant* transformer, the voltage can be measured between the three phases and ground.

### 6.3.1 Category A2 PV power plants

Protective functions with associated operating settings and trip time must match the values in the table below.

Protective function	Symbol	Setting		Trip time		Standard value
Overvoltage (step 2)	$U_{>>}$	$1.15 \cdot U_n$	V	200	ms	200 ms
Overvoltage (step 1)	$U_{>}$	$1.10 \cdot U_n$	V	60	s	60 s
Undervoltage (step 1)	$U_{<}$	$0.85 \cdot U_n$	V	10...60	s	50 s
Undervoltage (step 2) (***)	$U_{<<}$	$0.80 \cdot U_n$	V	100...200	ms	100 ms
Overfrequency	$f_{>}$	52.0	Hz	200	ms	200 ms
Underfrequency	$f_{<}$	47.0	Hz	200	ms	200 ms
Change of frequency (***)	$df/dt$	$\pm 2.5$	Hz/s	50...100	ms	80 ms

\*\*\*) One of the specified functions must be implemented.

Table 16 Requirements for category A2 PV power plants.

### 6.3.2 Category B PV power plants

Protective functions with associated operating settings and trip time must match the values in the table below.

Protective function	Symbol	Setting		Trip time		Standard value
Overvoltage (step 2)	$U_{>>}$	$1.15 \cdot U_n$	V	200	ms	200 ms
Overvoltage (step 1)	$U_{>}$	$1.10 \cdot U_n$	V	60	s	60 s
Undervoltage (step 1)	$U_{<}$	$0.90 \cdot U_n$	V	10...60	s	10 s
Overfrequency	$f_{>}$	52	Hz	200	ms	200 ms
Underfrequency	$f_{<}$	47	Hz	200	ms	200 ms
Change of frequency	$df/dt$	$\pm 2.5$	Hz/s	50...100	ms	80 ms

Table 17 Requirements for category B PV power plants.

### 6.3.3 Category C PV power plants

Protective functions with associated operating settings and trip time must match the values in the table below.

Protective function	Symbol	Setting		Trip time		Standard value
Overvoltage (step 3)	$U_{>>>}$	$1.20 \cdot U_n$	V	0...100	ms	100 ms
Overvoltage (step 2)	$U_{>>}$	$1.15 \cdot U_n$	V	100...200	ms	200 ms
Overvoltage (step 1)	$U_{>}$	$1.10 \cdot U_n$	V	60	s	60 s
Undervoltage (step 1)	$U_{<}$	$0.90 \cdot U_n$	V	10...60	s	10 s
Overfrequency	$f_{>}$	52	Hz	200	ms	200 ms
Underfrequency	$f_{<}$	47	Hz	200	ms	200 ms
Change of frequency	$df/dt$	$\pm 2.5$	Hz/s	50...100	ms	80 ms

Table 18 Requirements for category C PV power plants.

### 6.3.4 Category D PV power plants

Protective functions with associated operating settings and trip time must match the values in the table below.

Protective function	Symbol	Setting		Trip time		Standard value
Overvoltage (step 3)	$U_{>>>}$	$1.20 \cdot U_n$	V	0...100	ms	100 ms
Overvoltage (step 2)	$U_{>>}$	$1.15 \cdot U_n$	V	100...200	ms	200 ms
Overvoltage (step 1)	$U_{>}$	$1.10 \cdot U_n$	V	60	s	60 s
Undervoltage (step 1)	$U_{<}$	$0.90 \cdot U_n$	V	10...60	s	10 s
Overfrequency	$f_{>}$	52	Hz	200	ms	200 ms
Underfrequency	$f_{<}$	47	Hz	200	ms	200 ms
Change of frequency	$df/dt$	$\pm 2.5$	Hz/s	50...100	ms	80 ms

Table 19 Requirements for category D PV power plants.

## 7. Exchange of signals and data communication

### 7.1 Data communication requirements

To ensure the operation of the *public electricity supply grid*, the *plant* must be prepared for data communication between the *plant operator* and the *transmission system operator* as well as the *electricity supply undertaking* in the *plant's* communication interface in line with this regulation.

#### 7.1.1 Category A2 PV power plants

A category A2 *PV power plant* must be prepared to receive external signals for production 'Stop' and 'Released for start'.

The *plant* may start production again when the normal operating conditions specified in section 3.2 have been met, and the 'Released for start' signal has been received.

The signals must be accessible via a terminal strip or in the *PCOM* interface via commands in accordance with the specifications in section 7.3.

#### 7.1.2 Category B PV power plants

A category B *PV power plant* must be prepared to receive external signals for production 'Stop' and 'Released for start'.

The *plant* may start production again when the normal operating conditions specified in section 3.2 have been met, and the 'Released for start' signal has been received.

These signals must be accessible via a terminal strip or in the *PCOM* interface via commands as specified in section 7.3.

#### 7.1.3 Category C and D PV power plants

A category C and D *PV power plant* must be capable of exchanging the information in the *PCOM* interface specified in sections 7.6 and 7.7.

Signals must be accessible in the *PCOM* interface via commands as specified in section 7.3.

It must be possible to obtain correct measurements and maintain data communication in all situations, including when *PV power plants* are shut down and the grid is dead.

Local back-up supply must as a minimum ensure the logging of relevant measurements and data and ensure the controlled shutdown of the *PV power plant's* control and monitoring system.

Logging in connection with a shutdown must be performed at minute level.

### 7.2 Measurement requirements

The requirements specified in this subsection apply to *PV power plants* of all sizes.

Specific requirements for installed measuring equipment and measuring accuracy that must be available in order for a *PV power plant* to be connected to the *public electricity supply grid* are specified in the following regulations:

1. Regulation D1 'Settlement metering' [ref. 12]
2. Regulation D2 'Technical requirements for electricity metering' [ref. 13]
3. Technical regulation TR 5.8.1 'Metering data for system operation purposes' [ref. 10].

Compliance with the above-mentioned regulations must be verified by the meter operator as part of the checks and tests that form the basis for a final approval of the grid connection.

The latest versions of the applicable regulations are available on the *transmission system operator's* website at [www.energinet.dk](http://www.energinet.dk).

### 7.3 Data communication

If possible, information for a *PV power plant* must be named, modelled and grouped as specified in IEC/TR 61850-90-7 [ref. 26], and/or as described in SUNSPEC Alliance's inverter control profile. Inverters which are certified in accordance with SUNSPEC Alliance's requirements are considered to fulfil this requirement. See more details at [www.sunspec.org](http://www.sunspec.org) [ref. 35].

For a *PV power plant*, information exchange must be implemented using a protocol stack as specified in IEC 61850-8-1 [ref. 27], with mapping to IEC-60870-5-104 [ref. 8].

The protocol stack must be configured so that the *PV power plant* as a minimum can communicate with two master units.

The final solution must be agreed with the *transmission system operator* and the *electricity supply undertaking*.

Data communication with the *plant* must be available to the *transmission system operator* and the *electricity supply undertaking* in the *plant's* communication interface referred to as *PCOM*, as shown in Figure 3.

Information, measuring signals and activation options specified in this section must be established and must be available to the respective parties as indicated for the individual *plant* sizes in the following sections.

Activation of the individual functions in the *plants* and configuration of the specific parameters must fulfil the requirements stated in Technical regulation 5.8.1 [ref. 10].

Online communication is required for all *PV power plants*, regardless of category.

The specific requirements for the amount of information and signals are specified in the following sections for the individual *plant categories*.

#### 7.4 Category A2 PV power plants

Capability to establish online communication is required for category A2 *PV power plants*.

As a minimum, *PV power plants* in this category must be able to exchange the following signals:

Signal #	Signal description
A1.1	Stop signal
A1.2	Holding signal – 'Released for start'

Table 20 Requirements for information exchange with a category A2 *PV power plant*.

As a minimum, it must be possible to activate/deactivate and configure parameters for the *frequency response* function as well as the active and reactive power control functions via online communication, a control panel, relay switches or external signals. Parameters are listed in the table below.

A1.3	Active power control – <i>ramp rate constraint</i>
A1.4	Active power control – ramp rate for upward regulation of active power
A1.5	Active power control – ramp rate for downward regulation of active power
A1.6	Active power control – <i>absolute power constraint</i>
A1.7	Active power control – desired maximum active power
A1.8	Reactive power control – <i>Q control</i>
A1.9	Reactive power control – <i>Power Factor control</i>
A1.10	Reactive power control – <i>automatic Power Factor control</i>
A1.11	<i>Frequency response</i> – <i>droop</i> for downward regulation from $f_R$
A1.12	<i>Frequency response</i> – initial frequency for <i>frequency response</i> – $f_R$

Table 21 Requirements for control function parameters – A2.

#### 7.5 Category B PV power plants

Capability to establish online communication is required for category B *PV power plants*.

As a minimum, *PV power plants* in this category must be able to exchange the following signals in accordance with the specifications in section 7.3:

Signal #	Signal description
B1.1	Switch gear status in the <i>plant's Point of Connection</i>
B1.2	Active power kW – measured in the <i>Point of Connection</i>
B1.3	Active power kW – set point for active power
B1.4	Reactive power MVar – measured in the <i>Point of Connection</i>
B1.5	Stop signal
B1.6	Holding signal – 'Released for start'



Table 22 Requirements for information exchange with a category B PV power plant.

As a minimum, it must be possible to activate/deactivate and configure parameters for the *frequency response* function as well as the active and reactive power control functions via online communication, a control panel, relay switches or external signals. Parameters are listed in the table below.

B1.7	Active power control – <i>ramp rate constraint</i>
B1.8	Active power control – ramp rate for upward regulation of active power
B1.9	Active power control – ramp rate for downward regulation of active power
B1.10	Active power control – <i>absolute power constraint</i>
B1.11	Active power control – desired maximum active power
B1.12	Reactive power control – <i>Q control</i>
B1.13	Reactive power control – <i>Power Factor control</i>
B1.14	Reactive power control – <i>automatic Power Factor control</i>
B1.15	<i>Frequency response</i> – <i>droop</i> for downward regulation from $f_R$
B1.16	<i>Frequency response</i> – initial frequency for <i>frequency response</i> – $f_R$

Table 23 Requirements for control function parameters for category B PV power plants.

## 7.6 Category C PV power plants

Online communication is required for category C PV power plants.

As a minimum, PV power plants in this category must be able to exchange the following signals in accordance with the specifications in section 7.3:

Signal #	Signal description
C1.1	Switch gear status in the <i>plant's Point of Connection (POC)</i>
C1.2	Active power kW – measured in the <i>Point of Connection</i>
C1.3	Active power kW – set point for active power
C1.4	Active power control – <i>ramp rate constraint</i> activated/deactivated
C1.5	Active power control – ramp rate for upward regulation of active power
C1.6	Active power control – ramp rate for downward regulation of active power
C1.7	Active power control – <i>absolute constraint</i> activated/deactivated
C1.8	Active power control – max active power – set point for absolute production constraint
C1.9	Active power control – <i>delta constraint</i> activated/deactivated
C1.10	Active power control – desired regulating reserve – $P_{\text{delta}}$
C1.11	Reactive power MVAR – measured in the <i>Point of Connection</i>
C1.12	<i>Power Factor PF</i> – measured in the <i>Point of Connection</i>
C1.13	<i>Power Factor</i> set point – desired <i>Power Factor</i> in the <i>Point of Connection</i>
C1.14	Reactive power control – activated/deactivated
C1.15	Reactive power control – desired reactive power in the <i>Point of Connection</i>
C1.16	Voltage – voltage measured in the <i>voltage reference point</i>
C1.17	<i>Voltage control</i> – activated/deactivated
C1.18	<i>Voltage control</i> – voltage measured in the <i>Point of Connection</i>
C1.19	<i>Voltage control</i> – <i>voltage control droop</i>

C1.20	<i>Voltage control</i> – desired voltage in the <i>voltage reference point</i>
C1.21	<i>Frequency response</i> – initial frequency for <i>frequency response</i> – $f_R$
C1.22	<i>Frequency control</i> – frequency measured in the <i>Point of Connection</i>
C1.23	<i>Frequency control</i> – activated/deactivated
C1.24	<i>Frequency control</i> – control limit – low – $f_{\min}$
C1.25	<i>Frequency control</i> – control limit – high – $f_{\max}$
C1.26	<i>Frequency control</i> – initial frequency for control band – $f_1$
C1.27	<i>Frequency control</i> – initial frequency for dead band – $f_2$
C1.28	<i>Frequency control</i> – final frequency for dead band – $f_3$
C1.29	<i>Frequency control</i> – final frequency for control band – $f_4$
C1.30	<i>Frequency control</i> – final frequency for control up to $f_5$
C1.31	<i>Frequency control</i> – final frequency for control up to $f_6$
C1.32	<i>Frequency control</i> – <i>droop</i> 1 for control from $f_1$ to $f_2$
C1.33	<i>Frequency control</i> – <i>droop</i> 2 for control from $f_3$ to $f_4$
C1.34	<i>Frequency control</i> – <i>droop</i> 3 for control from $f_4$ to $f_5$
C1.35	<i>Frequency control</i> – <i>droop</i> 4 for downward regulation from $f_5$ to $f_6$
C1.36	<i>Frequency control</i> – frequency limit for reclosure – $f_7$
C1.37	System protection
C1.38	Stop signal
C1.39	Holding signal – 'Released for start'

Table 24 Requirements for information exchange with a category C PV power plant.

A more detailed description of the signals can be found in the document 'Guidelines on signal list – TR 3.2.2' [ref. 39] which is available electronically at [www.energinet.dk](http://www.energinet.dk).

To ensure security of supply, the *transmission system operator* must at all times be able to activate or deactivate the required control functions, including changing the current function settings via set points and activation commands..

## 7.7 Category D PV power plants

Online communication is required for category D PV power plants.

As a minimum, PV power plants in this category must be able to exchange the following signals in accordance with the specifications in section 7.3:

Signal #	Signal description
D1.1	Switch gear status in the <i>plant's Point of Connection</i>
D1.2	Active power kW – measured in the <i>Point of Connection</i>
D1.3	Active power kW – set point for active power
D1.4	Active power control – <i>ramp rate constraint</i> activated/deactivated
D1.5	Active power control – ramp rate for upward regulation of active power
D1.6	Active power control – ramp rate for downward regulation of active power
D1.7	Active power control – <i>absolute constraint</i> activated/deactivated
D1.8	Active power control – max active power – set point for absolute production constraint
D1.9	Active power control – <i>delta constraint</i> activated/deactivated

D1.10	Active power control – desired regulating reserve – $P_{\text{delta}}$
D1.11	Reactive power MVar – measured in the <i>Point of Connection</i>
D1.12	<i>Power Factor PF</i> – measured in the <i>Point of Connection</i>
D1.13	<i>Power Factor set point</i> – desired <i>Power factor</i> in the <i>Point of Connection</i>
D1.14	Reactive power control – activated/deactivated
D1.15	Reactive power control – desired reactive power in the <i>Point of Connection</i> – set point
D1.16	Voltage – voltage measured in the <i>voltage reference point</i>
D1.17	<i>Voltage control</i> – activated/deactivated
D1.18	<i>Voltage control</i> – voltage measured in the <i>Point of Connection</i>
D1.19	<i>Voltage control</i> – <i>voltage control droop</i>
D1.20	<i>Voltage control</i> – desired voltage in the <i>voltage reference point</i> – set point
D1.21	<i>Frequency response</i> – initial frequency for <i>frequency response</i> – $f_R$
D1.22	<i>Frequency control</i> – frequency measured in the <i>Point of Connection</i>
D1.23	<i>Frequency control</i> – activated/deactivated
D1.24	<i>Frequency control</i> – control limit – low – $f_{\text{min}}$
D1.25	<i>Frequency control</i> – control limit – high – $f_{\text{max}}$
D1.26	<i>Frequency control</i> – initial frequency for control band – $f_1$
D1.27	<i>Frequency control</i> – initial frequency for dead band – $f_2$
D1.28	<i>Frequency control</i> – final frequency for dead band – $f_3$
D1.29	<i>Frequency control</i> – final frequency for control band – $f_4$
D1.30	<i>Frequency control</i> – final frequency for control up to $f_5$
D1.31	<i>Frequency control</i> – final frequency for control up to $f_6$
D1.32	<i>Frequency control</i> – <i>droop 1</i> for control from $f_1$ to $f_2$
D1.33	<i>Frequency control</i> – <i>droop 2</i> for control from $f_3$ to $f_4$
D1.34	<i>Frequency control</i> – <i>droop 3</i> for control from $f_4$ to $f_5$
D1.35	<i>Frequency control</i> – <i>droop 4</i> for downward regulation from $f_5$ to $f_6$
D1.36	<i>Frequency control</i> – frequency limit for reclosure – $f_7$
D1.37	System protection
D1.38	Stop signal
D1.39	Holding signal – 'Released for start'

Table 25 Requirements for information exchange with a category D PV power plant.

A more detailed description of the signals can be found in the document 'Guidelines on signal list – TR 3.2.2' [ref. 39] which is available electronically at [www.energinet.dk](http://www.energinet.dk).

To ensure security of supply, the *transmission system operator* must at all times be able to activate or deactivate the required control functions, including changing the current function settings via set points and activation commands.

## 7.8 Fault incident recording

The requirements for recording fault incidents in the *public electricity supply grid* apply to category D PV power plants.

Logging must be performed using electronic equipment that can be configured, as a minimum, to log relevant incidents for the signals below in the *Point of Connection* in case of faults in the *public electricity supply grid*.

In the *Point of Connection*, the *plant owner* must install logging equipment which records, as a minimum:

- Voltage for each phase for the *PV power plant*
- Power for each phase for the *PV power plant*
- Active power for the *PV power plant* (can be computed values)
- Reactive power for the *PV power plant* (can be computed values)
- Frequency for the *PV power plant* (can be computed values).

Logging must be performed as correlated time series of measuring values from 10 seconds before the incident until 60 seconds after the incident.

Minimum sample frequency for all fault logs must be 1 kHz.

The specific settings for incident-based logging must be agreed with the *transmission system operator* upon commissioning of the *PV power plant*.

All measurements and data to be collected in accordance with Technical regulation 5.8.1 [ref. 10] must be logged with time stamps and an accuracy that ensures that such measurements and data can be correlated with each other and with similar recordings in the *public electricity supply grid*.

Time stamping of incidents and data must refer to *UTC* with a 10 ms accuracy or higher.

Logs must be filed for at least three months from the time of the fault situation. However, the maximum number of incidents to be recorded is 100.

Upon request, the *electricity supply undertaking* and the *transmission system operator* must be granted access to logged and relevant recorded information in *COMTRADE* format [ref. 34].

## **7.9 Requesting metered data and documentation**

The requirements in this section apply to category D *PV power plants*.

The *electricity supply undertaking* and the *transmission system operator* are entitled to request relevant information about a *PV power plant* at any time. Expenses relating to such request must be paid by the *plant owner*.

The *transmission system operator* can request metered data and fault recorder data collected for the *PV power plant* for a period of up to three months back in time.

At any time, the *electricity supply undertaking* and the *transmission system operator* are entitled to request verification and documentation that a *PV power plant* is in compliance with the provisions of this regulation. Such requests must be based on metered data and/or calculations specified by the *electricity supply undertaking* or the *transmission system operator*.

## 8. Verification and documentation

The *plant owner* is responsible for ensuring that the *plant* complies with this technical regulation and for documenting that the requirements are met.

The *electricity supply undertaking* and the *transmission system operator* are entitled to request at any time verification and documentation that the *plant* complies with the provisions of this regulation.

The standard procedure regarding the approval and issue of a final grid connection permit for a *plant* is as follows:

1. Appendix 1 must be completed and submitted electronically to the *electricity supply undertaking*.
2. The *electricity supply undertaking* reviews and approves the documentation and determines whether any information is missing.
3. Once the documentation has been approved, a final grid connection permit can be issued.

### 8.1 Documentation requirements

R Required documentation to be submitted for the different *plant categories* is stated in the table below.

<b>Category</b> <b>Documentation</b>	<b>A2**)</b>	<b>B</b>	<b>C</b>	<b>D</b>
Supplier statement	X	X	X	X
Protective functions	X	X	X	X
Single-line representation	X	X	X	X
Power quality	X	X	X	X
Voltage dip	-	-	X	X
PQ diagram	-	-	X	X
Signal list	-	-	X	X
Dynamic simulation model	-	-	X	X
Verification report	-	-	X	X

X: Documentation that must be submitted.

\*\* ) May be included in the *positive list*.

*Table 26 Documentation requirements for PV power plants.*

### 8.1.1 Supplier statement

By signing a supplier statement, the supplier guarantees that the specific *plant* complies with all requirements specified in Technical regulation 3.2.2. All important *plant components* must be listed in the statement.

### 8.1.2 Protective functions

Documentation of protective functions is a list of the relay configurations applicable at the time of commissioning. These values must be stated in the documentation.

### 8.1.3 Single-line representation

A single-line representation is a drawing showing the main components of the *plant* and their electrical interconnections. As a minimum, the location of protective functions and metering points must be indicated in the diagram.

### 8.1.4 Power quality

Power quality is a collection of parameters characterising the quality of the power delivered. The verification report must document how the requirements in section 4 have been met. Examples of and instructions on how the individual power quality parameters can be calculated can be found in the document 'Guidelines on the calculation of power quality parameters – TR 3.2.2' [ref. 36].

### 8.1.5 Voltage dip

Voltage dip is the *plant's* ability to stay connected to the electricity system during a voltage dip. The *plant's* ability to stay connected to the grid must be documented using the electrical simulation model provided. Alternatively, type test data is supplied, demonstrating that the requirements have been met. Model simulations must show that the requirements in section 3.3.1 have been met.

### 8.1.6 PQ diagram

A PQ diagram is a figure illustrating the *plant's* properties and ability to deliver reactive power as a function of the *plant's* ability to deliver active power. Measurements must show that the requirements in section 5.3 have been met. Alternatively, type test data is supplied, demonstrating that the requirements have been met.

### 8.1.7 Signal list

The signal list is a list of the signals/information that needs to be exchanged between the parties that control and monitor a *plant*. Documentation proving that the signals specified in section 7.3 are present in the *PCOM* interface must be supplied as part of the verification report. The document 'Guidelines on signal list – TR 3.3.2' [ref. 39] provides a detailed description of the individual signals.

### 8.1.8 Dynamic simulation model

A 'dynamic simulation model' is a model of a *plant's* electrical properties and constraints. The electrical simulation model must comply with the requirements specified in section 9.

### 8.1.9 Verification report

A 'verification report' is a report on/documentation of completed tests, demonstrating that the required functions have been implemented and work as

intended with the configured parameters. The document 'Guidelines on verification report – TR 3.2.2' [ref. 38] may be used for inspiration.

## 8.2 Documentation requirements – category A2 PV power plants

The documentation requirements for *plant category A2* are divided into the following two sections.

### 8.2.1 Documentation for plants not included in the positive list

If the *plant* or *plant components* are not included in the *positive list*, the following documentation must be submitted to the *electricity supply undertaking* for approval no later than three months before the date of commissioning:

Appendix 1 (B1.1. ), duly completed and supplemented with the following documents:

1. CE declaration of conformity
2. Technical documentation proving that answers given in Appendix 1 (B1.1. ) are correct.

### 8.2.2 Documentation for plants included in the positive list

The supplier of a *plant* will often have had the *plant components* used added to the *positive list*, making the technical case processing easier.

If the *plant* or *plant components* are included in the *positive list*, the following documentation must be submitted to *the electricity supply undertaking* for approval:

Appendix 1 (B1.2. ), duly completed.

## 8.3 Procedure for inclusion of plants and plant components in the positive list

To request that a *plant* or *plant components* be included in the *positive list*, the following documentation must be submitted to [positivlister@danskenergi.dk](mailto:positivlister@danskenergi.dk):

Appendix 1 (B1.1. ), duly completed and supplemented with the following documents:

1. CE declaration of conformity
2. Technical documentation proving that answers given in Appendix 1 (B1.1. ) are correct.

The process for inclusion in the *positive list* is explained on the Danish Energy Association's website: [www.danskenergi.dk/positivlister](http://www.danskenergi.dk/positivlister)

## 8.4 Documentation requirements – category B PV power plants

Documentation must be provided in the form of preliminary data for the *PV power plant* which must be sent to the *electricity supply undertaking* no later than three months before the date of commissioning. The required documentation comprises the following:

- a. Supplier statement
- b. Protective functions

- c. Single-line representation
- d. Power quality.

The documentation form can be found in Appendix 1 (B1.3).

### **8.5 Documentation requirements – category C PV power plants**

Documentation must be provided in the form of preliminary data for the *PV power plant* which must be sent to the *electricity supply undertaking* no later than three months **before** the date of commissioning.

No later than three months **after** the date of commissioning, documentation must be provided in the form of specific data for the entire *PV power plant* which must be sent to the *electricity supply undertaking*. The required documentation comprises the following:

- a. Supplier statement
- b. Protective functions
- c. Single-line representation
- d. Power quality
- e. Voltage dip
- f. PQ diagram
- g. Signal list
- h. Dynamic simulation model
- i. Verification report.

The documentation form can be found in Appendix 1 (B1.4).

### **8.6 Documentation requirements – category D PV power plants**

The documentation must be provided in the form of preliminary data for the *PV power plant* which must be sent to the *electricity supply undertaking* no later than three months **before** the date of commissioning.

No later than three months **after** the date of commissioning, documentation must be provided in the form of specific data for the entire *PV power plant* which must be sent to the *electricity supply undertaking*. The required documentation comprises the following:

- a. Supplier statement
- b. Protective functions
- c. Single-line representation
- d. Power quality
- e. Voltage dip
- f. PQ diagram
- g. Signal list
- h. Dynamic simulation model
- i. Verification report.

The documentation form can be found in Appendix 1 (B1.5).



## 9. Electrical simulation model

The requirements in this section apply to all category C and D *PV power plants*.

For the purposes of analysing the *public electricity supply grid*, the *transmission system operator* must maintain and expand the simulation models continuously as new *PV power plants* are connected to the grid.

The simulation models are used to analyse the dynamic properties of the transmission and distribution grids, including stability.

From the design phase to the verification phase, the *plant owner* must keep the *transmission system operator* informed if the preliminary data can no longer be regarded as being indicative of the finally commissioned *PV power plant*.

The *plant owner* must provide the *transmission system operator* with the simulation models specified.

In pursuance of Section 84 a of the Danish Electricity Supply Act, the *transmission system operator* is bound by a duty of confidentiality where commercially sensitive information is concerned.

As an option, simulation models may be sent directly from the inverter supplier to the *transmission system operator*.

The *plant owner* is responsible for ensuring that the correct set of data is submitted at the right time.

### 9.1 Simulation model requirements

The simulation model for the entire *PV power plant* must provide a dynamical description of the electrical properties, as seen from the *public electricity supply grid*.

The simulation model must be supplied in the form of a block diagram which mainly by means of logical and mathematical functions – primarily transfer functions in the Laplace/z domain – describes the properties of the *PV power plant*.

The simulation model must be accompanied by model descriptions which as a minimum comprise function descriptions of the main elements of the model and detailed descriptions of the individual model components and associated model parameters.

A simulation model consisting of compiled code is acceptable provided the source code is included.

A simulation model with encrypted parts will not be accepted, as the *transmission system operator shall* be able to include the *plant* model in the modelling of the *public electricity supply grid*.

The simulation model must comprise all control functions as required in section 5.

The simulation model must include all protective functions that can be activated during all relevant incidents and faults in the *public electricity supply grid* as required in section 6.

It must be possible to use the simulation model to simulate root-mean-square (RMS) values in the synchronous system (positive sequence).

It must be possible to use the simulation model to simulate root-mean-square (RMS) values in the individual phases during asymmetrical incidents and faults in the *public electricity supply grid*.

As a minimum, it must be possible to use the simulation model in the 47-53 Hz frequency range and in the 0-1.4 p.u. voltage range.

The simulation model must be able to describe the dynamic reply from the *PV power plant* for at least 30 seconds after each incident and fault in the *public electricity supply grid*.

It must be possible to initialise the simulation model directly on the basis of a load-flow solution without subsequent iterations.

The simulation model must be numerically stable and capable of utilising numerical equation solvers with variable sample length.

## 9.2 Verification of simulation model

If the model is not verified by an accredited institute, the *plant owner* must submit measurements that the *transmission system operator* can use to verify the simulation model for the entire *plant*. The measurements must be submitted no later than three months after final commissioning of the *PV power plant*.

The simulation model for the entire *PV power plant* must be verified for all control types as required in section 5.

No later than three months before the final commissioning of the *PV power plant*, the practical performance of verification tests must be determined on the basis of the *plant owner's* proposal and in collaboration with the *transmission system operator*.

The *plant owner* is responsible for performing all verification tests and is also responsible for measuring equipment, data loggers and staff.

Measurements used to verify the simulation model for the entire *PV power plant* must be documented by the *plant owner* in a report containing detailed descriptions of each individual test.

The time series measurements used to verify the simulation model must be enclosed with the verification report in *COMTRADE* format [ref. 34].

## 9.3 Category C PV power plants

The *transmission system operator* requires a dynamic simulation model for the entire *PV power plant*.

The *plant owner* must submit a simulation model for the entire *PV power plant*, including the *plant controller*, if any, no later than three months after commissioning.

The content and level of detail of the simulation models for the *plant controller* and for the individual inverter type must be such that they can be readily integrated and subsequently appear as a single fully functional simulation model as required in section 9.1.

The simulation model must be verified as specified in section 9.2.

The *plant owner* must supply data for the *plant infrastructure* upon request.

#### **9.4 Category D PV power plants**

The *transmission system operator* requires a dynamic simulation model for the entire *PV power plant*.

The *plant owner* must submit a simulation model for the entire *PV power plant*, including the *plant controller* and *power infrastructure*, no later than three months after commissioning.

The content and level of detail of the simulation models for the *plant controller* and the individual inverter type must be such that they can be readily integrated and subsequently appear as a single fully functional simulation model as required in section 9.1.

The scope and level of detail of data for components and parts that form part of the *power infrastructure* must also enable the construction of a single fully operational simulation model as required in section 9.1.

The simulation model must be verified as specified in section 9.2.

## Appendix 1 Documentation

Appendix 1 specifies the documentation requirements for the four *PV power plant* categories, see section 1.2.21.

The documentation, as specified in section 8, must be sent electronically to the *electricity supply undertaking*.

The technical documentation must contain configuration parameters and configuration data applicable to the *PV power plant* at the time of commissioning.

All subsections in the appendix must be filled in for the *plant* in question.

If information changes after the time of commissioning, updated documentation must be submitted as required in section 2.2.

A template for Appendix 1 for the various *plant categories* is available on the website [www.energinet.dk](http://www.energinet.dk).

### B1.1. Appendix 1 for plant category A2 not listed on the positive list

The documentation form must be filled in with data for the *PV power plant* valid at the time of commissioning and sent to the *electricity supply undertaking*.

#### B1.1.1. Identification

<i>Plant</i>	Description of the <i>plant</i> :
GSRN number	
<i>Plant owner</i> name and address	
<i>Plant owner</i> tel. no.	
<i>Plant owner</i> e-mail	
Type/model	
<i>Voltage (nominal)</i>	
<i>Rated power</i> (data sheet)	

#### B1.1.2. Power quality

For each power quality parameter, indicate how the result was achieved.

##### B1.1.2.1. Voltage changes

Are the voltage changes for the entire <i>plant</i> below the limit value?	Yes <input type="checkbox"/>
Where to find documentation that this requirement has been met?	No <input type="checkbox"/>

**B1.1.2.2. DC content**

<p>Does the DC content at normal operation exceed 0.5% of nominal current?</p> <p>Where to find documentation that this requirement has been met?</p>	<p>Yes <input type="checkbox"/></p> <p>No <input type="checkbox"/></p>
---	--

**B1.1.2.3. Asymmetry**

<p>Does the asymmetry at normal operation and during faults exceed 16 A?</p> <p>Where to find the documentation that this requirement has been met?</p>	<p>Yes <input type="checkbox"/></p> <p>No <input type="checkbox"/></p>
<p>In case of a <i>PV power plant</i> made up of single-phased <i>electricity-generating units</i>, have you taken measures to ensure that the above limit is not exceeded?</p> <p>Where to find documentation that this requirement has been met?</p>	<p>Yes <input type="checkbox"/></p> <p>No <input type="checkbox"/></p>

**B1.1.2.4. Flicker**

<p>Is the <i>flicker</i> contribution for the entire <i>plant</i> below the limit value?</p> <p>Where to find documentation that this requirement has been met?</p>	<p>Yes <input type="checkbox"/></p> <p>No <input type="checkbox"/></p>
---	--

**B1.1.2.5. Harmonic distortions**

<p>Are all <i>harmonic distortions</i> for the entire <i>plant</i> below the limit values?</p> <p>Where to find documentation that this requirement has been met?</p>	<p>Yes <input type="checkbox"/></p> <p>No <input type="checkbox"/></p>
---	--

**B1.1.3. Connection and synchronisation**

<p>Can the <i>PV power plant</i> be started and generate power continuously within the <i>normal production</i> range, limited only by the protective settings?</p> <p>Where to find documentation that this requirement has been met?</p>	<p>Yes <input type="checkbox"/></p> <p>No <input type="checkbox"/></p>
<p>Do connection and synchronisation occur three minutes, at the earliest, after voltage and frequency have come within the <i>normal production</i> range?</p> <p>Where to find documentation that this requirement has been met?</p>	<p>Yes <input type="checkbox"/></p> <p>No <input type="checkbox"/></p>

**B1.1.4. Active power control at overfrequency**

<p>Is the <i>PV power plant</i> equipped with a <i>frequency response function</i>?</p> <p>Is the function activated?</p> <p>Where to find documentation that these requirements have been met?</p>	<p>Yes <input type="checkbox"/></p> <p>No <input type="checkbox"/></p> <p>Yes <input type="checkbox"/></p> <p>No <input type="checkbox"/></p>
---	---

**B1.1.5. Absolute power constraint function**

<p>Is the <i>PV power plant</i> equipped with an <i>absolute power constraint function</i>?</p> <p>Is the function activated?</p> <p>Where to find documentation that these requirements have been met?</p>	<p>Yes <input type="checkbox"/></p> <p>No <input type="checkbox"/></p> <p>Yes <input type="checkbox"/></p> <p>No <input type="checkbox"/></p>
---	---

**B1.1.6. Ramp rate constraint function**

Is the <i>PV power plant</i> equipped with a <i>ramp rate constraint</i> function?	Yes <input type="checkbox"/> No <input type="checkbox"/>
Is the function activated?	Yes <input type="checkbox"/> No <input type="checkbox"/>
Where to find documentation that these requirements have been met?	

**B1.1.7. Reactive power control**

Reactive power can be controlled by means of	<i>Q control</i> <input type="checkbox"/> <i>Power factor control</i> <input type="checkbox"/> <i>Automatic power factor control</i> <input type="checkbox"/>
--	---

**B1.1.8. Q control**

Is the control function activated with a set point of _____ VAR? (Value may not differ from 0 VAR unless agreed with the <i>electricity supply undertaking</i> ).	Yes <input type="checkbox"/> No <input type="checkbox"/>
Where to find documentation that this requirement has been met?	

**B1.1.9. Power factor control**

Is the control function deactivated?	Yes <input type="checkbox"/> No <input type="checkbox"/>
Where to find documentation that this requirement has been met?	

**B1.1.10. Automatic power factor control**

Is the control function deactivated?	Yes <input type="checkbox"/> No <input type="checkbox"/>
Where to find documentation that this requirement has been met?	



**B1.1.11. Protection against electricity system faults****B1.1.11.1. Relay settings**

In the table below, indicate the values at the time of commissioning.

Protective function	Symbol	Setting		Trip time	
Overvoltage (step 2)	$U_{>>}$		V		ms
Overvoltage (step 1)	$U_{>}$		V		s
Undervoltage (step 1)	$U_{<}$		V		s
Undervoltage (step 2)	$U_{<<}$		V		ms
Overfrequency	$f_{>}$		Hz		ms
Underfrequency	$f_{<}$		Hz		ms
Change of frequency	$df/dt$		Hz/s		ms

**B1.1.11.2. Central protection**

<p>Has a central protection unit been installed?</p> <p>Where is it located?</p> <p>Where to find documentation that these requirements have been met?</p>	<p>Yes <input type="checkbox"/></p> <p>No <input type="checkbox"/></p> <p><i>PCI</i> <input type="checkbox"/></p> <p><i>POC</i> <input type="checkbox"/></p>
<p>Has consumption been connected after the protection unit?</p> <p>Where to find documentation that this requirement has been met?</p>	<p>Yes <input type="checkbox"/></p> <p>No <input type="checkbox"/></p>

**B1.1.12. Signature**

Date of commissioning	
Company	
Person responsible for commissioning	
Signature	

## B1.2. Appendix 1 for plant category A2 listed on the positive list

The documentation form must be filled in with data for the *PV power plant* at the time of commissioning and sent to *electricity supply undertaking*.

### B1.2.1. Identification

<i>Plant</i>	Description of the <i>plant</i> :
GSRN number	
<i>Plant owner</i> name and address	
<i>Plant owner</i> tel. no.	
<i>Plant owner</i> e-mail	
Type/model	
<i>Voltage (nominal)</i>	
<i>Rated power</i> (data sheet)	

### B1.2.2. Active power control at overfrequency

Is the <i>PV power plant</i> equipped with a <i>frequency response</i> function?	Yes <input type="checkbox"/> No <input type="checkbox"/>
Is the function activated?	Yes <input type="checkbox"/> No <input type="checkbox"/>

### B1.2.3. Absolute power constraint function

Is the <i>PV power plant</i> equipped with an <i>absolute power constraint</i> function?	Yes <input type="checkbox"/> No <input type="checkbox"/>
Is the function activated?	Yes <input type="checkbox"/> No <input type="checkbox"/>

**B1.2.4. Reactive power control**

Reactive power can be controlled by means of	<i>Q control</i> <input type="checkbox"/> <i>Power factor control</i> <input type="checkbox"/> <i>Automatic power factor control</i> <input type="checkbox"/>
--	---

**B1.2.5. Q control**

Is the control function activated with a set point of _____ VAR? (Value may not differ from 0 VAR unless agreed with the <i>electricity supply undertaking</i> ).	Yes <input type="checkbox"/> No <input type="checkbox"/>
--	---

**B1.2.6. Power factor control**

Is the control function deactivated?	Yes <input type="checkbox"/> No <input type="checkbox"/>
--------------------------------------	---

**B1.2.7. Automatic power factor control**

Is the control function deactivated?	Yes <input type="checkbox"/> No <input type="checkbox"/>
--------------------------------------	---

**B1.2.8. Protection against electricity system faults****B1.2.8.1. Relay settings**

In the table below, indicate the values at the time of commissioning.

Protective function	Symbol	Setting		Trip time	
Overvoltage (step 2)	$U_{>>}$		V		ms
Overvoltage (step 1)	$U_{>}$		V		s
Undervoltage (step 1)	$U_{<}$		V		s
Undervoltage (step2)	$U_{<<}$		V		ms
Overfrequency	$f_{>}$		Hz		ms
Underfrequency	$f_{<}$		Hz		ms
Change of frequency	$df/dt$		Hz/s		ms

**B1.2.8.2. Central protection**

<p>Has a central protection unit been installed?</p> <p>Where is it located?</p>	<p>Yes <input type="checkbox"/></p> <p>Nej <input type="checkbox"/></p> <p><i>PCI</i> <input type="checkbox"/></p> <p><i>POC</i> <input type="checkbox"/></p>
<p>Has consumption been connected after the protection unit?</p>	<p>Yes <input type="checkbox"/></p> <p>No <input type="checkbox"/></p>

**B1.2.9. Signature**

Date of commissioning	
Company	
Person responsible for commissioning	
Signature	

### B1.3. Appendix 1 for plant category B

The documentation form must be filled in with data for the *PV power plant* valid at the time of commissioning and sent to the *electricity supply undertaking*.

#### B1.3.1. Identification

<i>Plant</i>	Description of the <i>plant</i> :
GSRN number	
<i>Plant owner</i> name and address	
<i>Plant owner</i> tel. no.	
<i>Plant owner</i> e-mail	
Type/model	
<i>Voltage (nominal)</i>	
<i>Rated power</i> (data sheet)	

#### B1.3.2. Voltage dip tolerances

Will the <i>PV power plant</i> remain connected to the <i>public electricity supply grid</i> during voltage dips as specified in section 3.3.1?	Yes <input type="checkbox"/> No <input type="checkbox"/>
Has a simulation been enclosed, documenting that the Low Voltage Fault Ride Through (LVFRT) requirements have been met?  If No, how is compliance then documented?	Yes <input type="checkbox"/> No <input type="checkbox"/>

**B1.3.3. Voltage quality**

Please state how results were achieved for each power quality parameter.

Have the values been calculated?	Yes <input type="checkbox"/> No <input type="checkbox"/>
Have the values been measured?	Yes <input type="checkbox"/> No <input type="checkbox"/>
Is a report enclosed, documenting that the calculations or measurements meet emission requirements?  If No, how are the calculations or measurements documented?	Yes <input type="checkbox"/> No <input type="checkbox"/>

**B1.3.3.1. DC content**

Does the DC content at normal operation exceed 0.5% of the nominal current?	Yes <input type="checkbox"/> No <input type="checkbox"/>
---	---

**B1.3.3.2. Asymmetry**

Does the asymmetry at normal operation and during faults exceed 16 A?	Yes <input type="checkbox"/> No <input type="checkbox"/>
In case of a <i>PV power plant</i> made up of single-phase <i>electricity-generating units</i> , have you taken measures to ensure that the above limit is not exceeded?	Yes <input type="checkbox"/> No <input type="checkbox"/>

**B1.3.3.3. Flicker**

Is the <i>flicker</i> contribution for the entire <i>PV power plant</i> below the limit value?	Yes <input type="checkbox"/> No <input type="checkbox"/>
--	---

**B1.3.3.4. Harmonic distortions**

Are all <i>harmonic distortions</i> for the entire <i>PV power plant</i> below the limit values?	Yes <input type="checkbox"/> No <input type="checkbox"/>
--	---

**B1.3.3.5. Interharmonic distortions**

Are all interharmonic distortions for the entire <i>PV power plant</i> below the limit values?	Yes <input type="checkbox"/> No <input type="checkbox"/>
--	---

**B1.3.3.6. Distortions from 2-9 kHz**

Is the emission of distortions with frequencies in the 2-9 kHz range lower than 0.2% of the <i>rated current</i> $I_n$ ?	Yes <input type="checkbox"/> No <input type="checkbox"/>
--	---

**B1.3.4. Connection and synchronisation**

Can the <i>PV power plant</i> be started and generate power continuously within the <i>normal production</i> range. limited only by the protective settings?	Yes <input type="checkbox"/> No <input type="checkbox"/>
Do connection and synchronisation occur three minutes, at the earliest, after the voltage and frequency have come within the <i>normal production</i> range?	Yes <input type="checkbox"/> No <input type="checkbox"/>

**B1.3.5. Active power control at overfrequency**

Is the <i>PV power plant</i> equipped with a <i>frequency response</i> function?	Yes <input type="checkbox"/> No <input type="checkbox"/>
--	---

**B1.3.6. Absolute power constraint function**

Is the <i>PV power plant</i> equipped with an <i>absolute power constraint</i> function?	Yes <input type="checkbox"/> No <input type="checkbox"/>
Is the function activated?	Yes <input type="checkbox"/> No <input type="checkbox"/>

**B1.3.7. Ramp rate constraint function**

Is the <i>PV power plant</i> equipped with a <i>ramp rate constraint</i> function?	Yes <input type="checkbox"/> No <input type="checkbox"/>
Is the function activated?	Yes <input type="checkbox"/> No <input type="checkbox"/>

**B1.3.8. Reactive power control**

Reactive power can be controlled by means of	<i>Q control</i> <input type="checkbox"/> <i>Power factor control</i> <input type="checkbox"/> <i>Automatic power factor control</i> <input type="checkbox"/>
--	---

**B1.3.9. Q control**

Is the control function activated with a set point of _____ VAr? (Value may not differ from 0 VAr unless agreed with the <i>electricity supply undertaking</i> ).	Yes <input type="checkbox"/> No <input type="checkbox"/>
--	---

**B1.3.10. Power factor control**

Is the control function deactivated?	Yes <input type="checkbox"/> No <input type="checkbox"/>
--------------------------------------	---

**B1.3.11. Automatic power factor control**

Is the control function deactivated?	Yes <input type="checkbox"/> No <input type="checkbox"/>
--------------------------------------	---



**B1.3.12. Protection against electricity system faults****B1.3.12.1. Relay settings**

In the table below, indicate the values at the time of commissioning.

Protective function	Symbol	Setting		Trip time	
Overvoltage (step 2)	$U_{>>}$		V		ms
Overvoltage (step 1)	$U_{>}$		V		s
Undervoltage (step 1)	$U_{<}$		V		s
Overfrequency	$f_{>}$		Hz		ms
Underfrequency	$f_{<}$		Hz		ms
Change of frequency	$df/dt$		Hz/s		ms

**B1.3.12.2. Central protection**

Has a central protection unit been installed?	Yes <input type="checkbox"/> No <input type="checkbox"/>
Where is it located?	<i>PCI</i> <input type="checkbox"/> <i>POC</i> <input type="checkbox"/>
Has consumption been connected after the protection unit?	Yes <input type="checkbox"/> No <input type="checkbox"/>

**B1.3.13. Single-line representation**

Is a single-line representation for the <i>plant</i> enclosed with the documentation?	Yes <input type="checkbox"/> No <input type="checkbox"/>
If No, when will the final single-line representation be provided?	

**B1.3.14. Signature**

Date of commissioning	
Company	
Person responsible for commissioning	
Signature	

### B1.4. Appendix 1 to plant category C

The documentation form must be filled in with preliminary data for the *PV power plant* and sent to the *electricity supply undertaking* no later than three months **before** the date of commissioning.

No later than three months **after** the date of commissioning, the documentation form must be filled in with specific data for the entire *PV power plant* and sent to the *electricity supply undertaking*.

The required documentation comprises the following:

#### B1.4.1. Identification

<i>Plant</i>	Description of the <i>plant</i> :
GSRN number	
<i>Plant owner</i> name and address	
<i>Plant owner</i> tel. no.	
<i>Plant owner</i> e-mail	
Type/model	
<i>Voltage (nominal)</i>	
<i>Rated power</i> (data sheet)	

#### B1.4.2. Voltage dip tolerances

Will the <i>plant</i> remain connected to the <i>public electricity supply grid</i> during voltage dips as specified in section 3.3.1?	Yes <input type="checkbox"/> No <input type="checkbox"/>
Has a simulation been enclosed, documenting that the Low Voltage Fault Ride Through (LVFRT) requirements have been met?  If No, how is compliance then documented?	Yes <input type="checkbox"/> No <input type="checkbox"/>

**B1.4.3. Voltage quality**

For each power quality parameter, indicate how the result was achieved.

Have the values been calculated?	Yes <input type="checkbox"/> No <input type="checkbox"/>
Have the values been measured?	Yes <input type="checkbox"/> No <input type="checkbox"/>
Is a report enclosed, documenting that the calculations or measurements meet the emission requirements?  If No, how are the calculations or measurements documented?	Yes <input type="checkbox"/> No <input type="checkbox"/>

**B1.4.3.1. DC content**

Does the DC content at normal operation exceed 0.5% of the nominal current?	Yes <input type="checkbox"/> No <input type="checkbox"/>
---	---

**B1.4.3.2. Asymmetry**

Does the asymmetry at normal operation and during faults exceed 16 A?	Yes <input type="checkbox"/> No <input type="checkbox"/>
In case of a <i>PV power plant</i> made up of single-phase <i>electricity-generating units</i> , have you taken measures to ensure that the above limit is not exceeded?	Yes <input type="checkbox"/> No <input type="checkbox"/>

**B1.4.3.3. Flicker**

Is the <i>flicker</i> contribution for the entire <i>PV power plant</i> below the limit value?	Yes <input type="checkbox"/> No <input type="checkbox"/>
--	---

**B1.4.3.4. Harmonic distortions**

Are all <i>harmonic distortions</i> for the entire <i>PV power plant</i> below the limit values?	Yes <input type="checkbox"/> No <input type="checkbox"/>
--	---

**B1.4.3.5. Interharmonic distortions**

Are all interharmonic distortions for the entire <i>PV power plant</i> below the limit values?	Yes <input type="checkbox"/> No <input type="checkbox"/>
--	---

**B1.4.3.6. Distortions from 2-9 kHz**

Emission of distortions with frequencies in the 2-9 kHz range is determined by the <i>electricity supply undertaking</i> . Is the requirement met?	Yes <input type="checkbox"/> No <input type="checkbox"/>
--	---

**B1.4.4. Connection and synchronisation**

Can the <i>plant</i> be started and generate power continuously within the <i>normal production</i> range, limited only by the protective settings?	Yes <input type="checkbox"/> No <input type="checkbox"/>
Do connection and synchronisation occur three minutes, at the earliest, after voltage and frequency have come within the <i>normal production</i> range?	Yes <input type="checkbox"/> No <input type="checkbox"/>

**B1.4.5. Active power control at overfrequency**

Is the <i>PV power plant</i> equipped with a <i>frequency response</i> function?	Yes <input type="checkbox"/> No <input type="checkbox"/>
--	---

**B1.4.6. Frequency control**

Is the <i>PV power plant</i> equipped with a <i>frequency control</i> function as specified in section 5.2.2?	Yes <input type="checkbox"/> No <input type="checkbox"/>
---	---

**B1.4.7. Absolute power constraint function**

Is the PV power <i>plant</i> equipped with an <i>absolute power constraint</i> function?	Yes <input type="checkbox"/> No <input type="checkbox"/>
Is the function activated?	Yes <input type="checkbox"/> No <input type="checkbox"/>

**B1.4.8. Delta power constraint function**

Is the <i>PV power plant</i> equipped with a <i>delta power constraint</i> function?	Yes <input type="checkbox"/> No <input type="checkbox"/>
Is the function activated?	Yes <input type="checkbox"/> No <input type="checkbox"/>

**B1.4.9. Ramp rate constraint function**

Is the <i>PV power plant</i> equipped with a <i>ramp rate constraint</i> function?	Yes <input type="checkbox"/> No <input type="checkbox"/>
Is the function activated?	Yes <input type="checkbox"/> No <input type="checkbox"/>

**B1.4.10. System protection**

Is the <i>PV power plant</i> equipped with a system protection function?	Yes <input type="checkbox"/> No <input type="checkbox"/>
Is the function activated?	Yes <input type="checkbox"/> No <input type="checkbox"/>

**B1.4.11. Reactive power control**

Reactive power can be controlled by means of	<i>Q control</i> <input type="checkbox"/> <i>Power factor control</i> <input type="checkbox"/> <i>Voltage control</i> <input type="checkbox"/>
--	--

**B1.4.12. Q control**

Is the control function activated with a set point of _____ VAR? (Value may not differ from 0 VAR unless agreed with the <i>electricity supply undertaking</i> ).	Yes <input type="checkbox"/> No <input type="checkbox"/>
--	---

**B1.4.13. Power factor control**

Is the control function deactivated?	Yes <input type="checkbox"/> No <input type="checkbox"/>
--------------------------------------	---

**B1.4.14. Voltage control**

Is the <i>plant</i> equipped with a <i>voltage control</i> function as specified in section 5.3.3?	Yes <input type="checkbox"/> No <input type="checkbox"/>
--	---

**B1.4.15. Protection against electricity system faults****B1.4.15.1. Relay settings**

In the table below, indicate the current values at the time of commissioning.

Protective function	Symbol	Setting		Trip time	
Overvoltage (step 3)	$U_{>>>}$		V		Ms
Overvoltage (step 2)	$U_{>>}$		V		Ms
Overvoltage (step 1)	$U_{>}$		V		S
Undervoltage (step 1)	$U_{<}$		V		S
Overfrequency	$f_{>}$		Hz		Ms
Underfrequency	$f_{<}$		Hz		Ms
Change of frequency	$df/dt$		Hz/s		Ms

**B1.4.15.2. Central protection**

Has a central protection unit been installed?	Yes <input type="checkbox"/> No <input type="checkbox"/>
If Yes, where is it located?	<i>PCI</i> <input type="checkbox"/> <i>POC</i> <input type="checkbox"/>
Has consumption been connected after the protection unit?	Yes <input type="checkbox"/> No <input type="checkbox"/>

**B1.4.16. Single-line representation**

Is a single-line representation for the <i>PV power plant</i> enclosed with the documentation?	Yes <input type="checkbox"/> No <input type="checkbox"/>
If No, when will the final single-line representation be provided?	

**B1.4.17. PQ diagram**

Has the final PQ diagram been submitted to the <i>electricity supply undertaking</i> ?	Yes <input type="checkbox"/> No <input type="checkbox"/>
If No, when will the final PQ diagram be provided?	

**B1.4.18. Signal list**

Has the final signal list been submitted to the <i>electricity supply undertaking</i> ?	Yes <input type="checkbox"/> No <input type="checkbox"/>
If No, when will the final signal list be provided?	

**B1.4.19. Simulation model**

Has the electrical simulation model for the <i>PV power plant</i> been submitted to the <i>electricity supply undertaking</i> ?	Yes <input type="checkbox"/> No <input type="checkbox"/>
If No, when will the final simulation model be provided?	

**B1.4.20. Verification report**

<p>Has the verification report been submitted to the <i>electricity supply undertaking</i>?</p> <p>If No, when will the verification report be provided?</p>	<p>Yes <input type="checkbox"/></p> <p>No <input type="checkbox"/></p>
--	--

**B1.4.21. Signature**

Date of commissioning	
Company	
Person responsible for commissioning	
Signature	



### B1.5. Appendix 1 for plant category D

The documentation form must be filled in with preliminary data for the *PV power plant* and sent to the *electricity supply undertaking* no later than three months **before** the date of commissioning.

No later than three months **after** the date of commissioning, the documentation form must be filled in with specific data for the entire *PV power plant* and sent to the *electricity supply undertaking*.

The required documentation comprises the following:

#### B1.5.1. Identification

<i>Plant</i>	Description of the <i>plant</i> :
GSRN number	
<i>Plant owner</i> name and address	
<i>Plant owner</i> tel. no.	
<i>Plant owner</i> e-mail	
Type/model	
<i>Voltage (nominal)</i>	
<i>Rated power (data sheet)</i>	

#### B1.5.2. Voltage dip tolerances

Will the PV power <i>plant</i> remain connected to the <i>public electricity supply grid</i> during voltage dips as specified in section 3.3.1?	Yes <input type="checkbox"/> No <input type="checkbox"/>
Has a simulation been enclosed, documenting that the Low Voltage Fault Ride Through (LVFRT) requirements have been met?  If No, how is compliance then documented?	Yes <input type="checkbox"/> No <input type="checkbox"/>

**B1.5.3. Voltage quality**

For each power quality parameter, indicated how the result was achieved.

Have the values been calculated?	Yes <input type="checkbox"/> No <input type="checkbox"/>
Have the values been measured?	Yes <input type="checkbox"/> No <input type="checkbox"/>
Is a report enclosed, documenting that the calculations or measurements meet the emission requirements?  If No, how are the calculations or measurements documented?	Yes <input type="checkbox"/> No <input type="checkbox"/>

**B1.5.3.1. DC content**

Does the DC content at normal operation exceed 0.5% of the nominal current?	Yes <input type="checkbox"/> No <input type="checkbox"/>
---	---

**B1.5.3.2. Asymmetry**

Does the asymmetry at normal operation and during faults exceed 16 A?	Yes <input type="checkbox"/> No <input type="checkbox"/>
In case of a <i>PV power plant</i> made up of single-phase <i>electricity-generating units</i> , have you ensured that the above limit is not exceeded?	Yes <input type="checkbox"/> No <input type="checkbox"/>

**B1.5.3.3. Flicker**

Is the <i>flicker</i> contribution for the entire <i>PV power plant</i> below the limit value?	Yes <input type="checkbox"/> No <input type="checkbox"/>
--	---

**B1.5.3.4. Harmonic distortions**

Are all <i>harmonic distortions</i> for the entire <i>PV power plant</i> below the limit values?	Yes <input type="checkbox"/> No <input type="checkbox"/>
--	---

**B1.5.3.5. Interharmonic distortions**

Are all interharmonic distortions for the entire <i>PV power plant</i> below the limit values?	Yes <input type="checkbox"/> No <input type="checkbox"/>
--	---

**B1.5.3.6. Distortions from 2-9 kHz**

Emission of distortions with frequencies in the 2-9 kHz range is determined by the <i>electricity supply undertaking</i> . Is the requirement met?	Yes <input type="checkbox"/> No <input type="checkbox"/>
--	---

**B1.5.4. Connection and synchronisation**

Can the <i>PV power plant</i> be started and generate power continuously within the <i>normal production</i> range, limited only by the protective settings?	Yes <input type="checkbox"/> No <input type="checkbox"/>
Do connection and synchronisation occur three minutes, at the earliest, after voltage and frequency have come within the <i>normal production</i> range?	Yes <input type="checkbox"/> No <input type="checkbox"/>

**B1.5.5. Active power control at overfrequency**

Is the <i>PV power plant</i> equipped with a <i>frequency response</i> function?	Yes <input type="checkbox"/> No <input type="checkbox"/>
--	---

**B1.5.6. Frequency control**

Is the <i>PV power plant</i> equipped with a <i>frequency control</i> function as specified in section 5.2.2?	Yes <input type="checkbox"/> No <input type="checkbox"/>
---	---

**B1.5.7. Absolute power constraint function**

Is the <i>PV power plant</i> equipped with an <i>absolute power constraint</i> function?	Yes <input type="checkbox"/> No <input type="checkbox"/>
Is the function activated?	Yes <input type="checkbox"/> No <input type="checkbox"/>

**B1.5.8. Delta power constraint function**

Is the <i>PV power plant</i> equipped with a <i>delta power constraint</i> function?	Yes <input type="checkbox"/> No <input type="checkbox"/>
Is the function activated?	Yes <input type="checkbox"/> No <input type="checkbox"/>

**B1.5.9. Ramp rate constraint function**

Is the <i>PV power plant</i> equipped with a <i>ramp rate constraint</i> function?	Yes <input type="checkbox"/> No <input type="checkbox"/>
Is the function activated?	Yes <input type="checkbox"/> No <input type="checkbox"/>

**B1.5.10. System protection**

Is the <i>PV power plant</i> equipped with a system protection function?	Yes <input type="checkbox"/> No <input type="checkbox"/>
Is the function activated?	Yes <input type="checkbox"/> No <input type="checkbox"/>

**B1.5.11. Reactive power control**

Reactive power can be controlled by means of	<i>Q control</i> <input type="checkbox"/> <i>Power factor control</i> <input type="checkbox"/> <i>Voltage control</i> <input type="checkbox"/>
--	--

**B1.5.12. Q control**

Is the control function activated with a set point of _____ VAR? (Value may not differ from 0 VAR unless agreed with the <i>electricity supply undertaking</i> ).	Yes <input type="checkbox"/> No <input type="checkbox"/>
--	---

**B1.5.13. Power factor control**

Is the control function deactivated?	Yes <input type="checkbox"/> No <input type="checkbox"/>
--------------------------------------	---

**B1.5.14. Voltage control**

Is the <i>PV power plant</i> equipped with a <i>voltage control</i> function as specified in section 5.3.3?	Yes <input type="checkbox"/> No <input type="checkbox"/>
---	---

**B1.5.15. Protection against electricity system faults****B1.5.15.1. Relay settings**

In the table below, indicate the values at the time of commissioning.

Protective function	Symbol	Setting		Trip time	
Overvoltage (step 3)	$U_{>>>}$		V		Ms
Overvoltage (step 2)	$U_{>>}$		V		Ms
Overvoltage (step 1)	$U_{>}$		V		S
Undervoltage (step 1)	$U_{<}$		V		S
Overfrequency	$f_{>}$		Hz		Ms
Underfrequency	$f_{<}$		Hz		Ms
Change of frequency	$df/dt$		Hz/s		Ms

**B1.5.15.2. Central protection**

Has a central protection unit been installed?	Yes <input type="checkbox"/> No <input type="checkbox"/>
Where is it located?	<i>PCI</i> <input type="checkbox"/> <i>POC</i> <input type="checkbox"/>
Has consumption been connected after the protection unit?	Yes <input type="checkbox"/> No <input type="checkbox"/>

**B1.5.16. Single-line representation**

Is a single-line representation for the <i>plant</i> enclosed with the documentation?	Yes <input type="checkbox"/> No <input type="checkbox"/>
If No, when will the final single-line representation be provided?	

**B1.5.17. PQ diagram**

Has the final PQ diagram been submitted to the <i>electricity supply undertaking</i> ?	Yes <input type="checkbox"/> No <input type="checkbox"/>
If No, when will the final PQ diagram be provided?	

**B1.5.18. Signal list**

Has the final signal list been submitted to the <i>electricity supply undertaking</i> ?	Yes <input type="checkbox"/> No <input type="checkbox"/>
If No, when will the final signal list be provided?	

**B1.5.19. Simulation model**

Has the electrical simulation model for the <i>PV power plant</i> been submitted to the <i>electricity supply undertaking</i> ?	Yes <input type="checkbox"/> No <input type="checkbox"/>
If No, when will the final simulation model be provided?	

**B1.5.20. Verification report**

<p>Has the verification report been submitted to the <i>electricity supply undertaking</i>?</p> <p>If No, when will the verification report be provided?</p>	<p>Yes <input type="checkbox"/></p> <p>No <input type="checkbox"/></p>
--	--

**B1.5.21. Signature**

Date of commissioning	
Company	
Person responsible for commissioning	
Signature	