



# Technical Regulation 3.2.1 for electricity-generation plants of 11 kW or lower

1.1		23.11.2010				DATE
		SFJ/KDJ				NAME
REV.	DESCRIPTION	PREPARED	CHECKED	REVIEWED	APPROVED	
		<b>35198/10</b>				
		35198/10.				

## Revision view

Chapter no.	Text	Version	Date
All	Transferred to new template; text adjustments made	1.1	23.11.2010
All	Updated following public consultation and notified to the Danish Energy Regulatory Authority	1.0	30.6.2008
All	Public consultation in connection with the ratification of EN50438	0.0	1.12.2007

**List of contents**

Revision view ..... 2

List of contents ..... 3

To the reader ..... 4

1. Terminology and definitions ..... 5

2. Objective, scope and regulatory provisions ..... 7

3. Installation requirements ..... 11

4. Network protection in the point of connection ..... 12

5. Voltage quality ..... 14

6. Notification and documentation ..... 15

Appendix 1. Documentation ..... 18

Appendix 2. Earlier provisions ..... 23

## To the reader

This regulation includes the technical and functional minimum requirements which *electricity-generation plants* with a *rated power* of 11 kW or lower must comply with if they are to be connected to the Danish network. The minimum requirements lie within the framework of the Danish Electricity Supply Act, see Executive Order no. 1115 of 8 November 2006 with subsequent amendments.

The regulation is structured so that **chapter 1** outlines the terminology and definitions used; **chapter 2** describes the administrative provisions and relevant references, while the technical and functional requirements are described in **chapter 3 onwards**.

The regulation makes extensive use of terminology and definitions, the most important of which are described in **chapter 1**. In the regulation, terminology and definitions are written in *italics*. Where relevant in relation to the applied European norm EN50438, the corresponding English terminology and definitions have been added.

The regulation is published by Energinet.dk and can be downloaded at [www.energinet.dk](http://www.energinet.dk).

# 1. Terminology and definitions

## 1.1 Plant owner

The *plant owner* is the legal owner of the *electricity-generation plant*.

## 1.2 Electricity-generation plant

Facility producing single-phase, two-phase or three-phase alternating current.

## 1.3 Public electricity supply network

Transmission grids and distribution networks the purpose of which is to transmit electricity for an indefinite group of electricity suppliers and consumers on the terms laid down by public authorities.

The transmission system is defined as the *public electricity supply network* with a *nominal voltage* greater than 100 kV, whereas the distribution system is defined as the *public electricity supply network* with a *nominal voltage* lower than 100 kV.

## 1.4 Point of common coupling

The *point of common coupling (PCC)* is the point in the *public electricity supply network* to which consumers are or can be connected. From an electrical point of view, the *point of common coupling* and the *point of connection* may coincide, but if this is not the case, it is always the *point of common coupling* that is placed closest to the *public electricity supply network*, see **Figure 1**. The *distribution network operator* determines the *point of common coupling*.

## 1.5 Rated power

The highest nominal electrical output of an *electricity-generation plant* at nominal operating conditions. Stated in kW or kVA.

## 1.6 Rated current

The highest nominal current supplied by an *electricity-generation plant* at nominal operating conditions.

## 1.7 Loss of mains (LoM)

Failure in the connection to the *public electricity supply network*.

## 1.8 Distribution network operator

Enterprise licensed to operate the distribution network. The *distribution network operator* is the enterprise to whose grid an *electricity-generation plant* is connected electrically.

## 1.9 Nominal voltage

Voltage in a *connection point* for which the power system is designated, eg 230 V single-phase or 230/400 V polyphase.

## 1.10 Interconnected electricity supply system

The *interconnected electricity supply system* is defined as the *public electricity supply network* and associated plants in a large geographical area which are interconnected with a view to joint operation.

### 1.11 Transmission system operator (TSO)

Enterprise entrusted with the overall responsibility for maintaining security of supply and ensuring the efficient utilisation of an *interconnected electricity supply system*.

Energinet.dk is the *transmission system operator*.

### 1.12 Point of connection

The *point of connection (POC)* is the point in the *public electricity supply network* to which the *electricity-generation plant* is connected. The connection can take the form of either a *direct network connection* or an *installation connection*. The *distribution network operator* determines the *point of connection*.

#### 1.12.1 Grid connection direct

The *electricity-generation plant* is connected directly to the *public electricity supply network* includes own service line and installation up to the *electricity-generation plant*.

#### 1.12.2 Grid connection in the installation

The *electricity-generation plant* is connected inside the electrical installation and use the electrical installation to the *public electricity supply network*.

**Figure 1** Typical installation connection of an electricity-generation plant shows a typical installation connection for a *small wind turbine*, but the same connection could also be used for solar plants or other types of *electricity-generation plants*. In the situation shown, the *point of common coupling (PCC)* and the *point of connection (POC)* coincide.

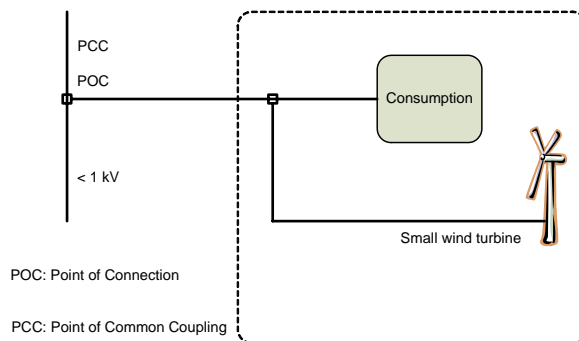

Figure 1 Typical installation connection of an electricity-generation plant

### 1.13 Regional transmission company

Company licensed to operate the transmission grid.

## 2. Objective, scope and regulatory provisions

### 2.1 Objective

The objective of Technical Regulation 3.2.1 (TR 3.2.1) is to specify the minimum technical and functional requirements, which an *electricity-generation plant* with a *rated power* of 11 kW or lower (maximum current up to 16 A per phase, however) must comply within the *point of connection* when connected to the *public electricity supply network*.

In pursuance of section 7(1) of the Danish Executive Order no. 1463 of 19 December 2005 on transmission system operation and the use of the electricity transmission grid etc., this regulation has been prepared following discussions with the distribution network operators and regional transmission companies. It has also been subjected to public consultation before being notified to the Danish Energy Regulatory Authority.

The regulation applies within the framework of the Danish Electricity Supply Act, see the Danish Executive Order no. 516 of 20 May 2010 with subsequent amendments.

The regulation substantiates and confirms the European norm EN50438 and thus contributes to harmonising the rules on grid connection of *electricity-generation plants* of 11 kW or lower in Europe. The regulation contains clarifications of and supplements to the provisions of EN50438.

An *electricity-generation plant* must comply with Danish legislation, including the Danish Heavy Current Regulation and the 'Joint Regulation' (*Fællesregulativet*). In areas not subject to Danish legislation, the CEN/CENELEC standards apply, and in areas where there are no such standards, the ISO and IEC standards apply.

### 2.2 Scope

An *electricity-generation plant* connected to the *public electricity supply network* must throughout its lifetime comply with the provisions of this regulation.

#### **New electricity-generation plants**

The regulation applies to all *electricity-generation plants* with a *rated power* of 11 kW or lower which are connected to the *public electricity supply network* and have been commissioned from 1 January 2011 onwards.

#### **Existing electricity-generation plants**

*Electricity-generation plants* with a *rated power* of 11 kW or lower which were connected to the *public electricity supply network* before 1 January 2011 must comply with the regulation in force at the time of commissioning.

#### **Changes to existing electricity-generation plants**

Existing *electricity-generation plants* to which substantial functional modifications are made must comply with the provisions of this regulation relating to such changes. In case of doubt, the *transmission system operator* decides whether a specific modification is substantial.

### 2.3 Delimitation

The regulation does not apply to *electricity-generation plants* where several small plants connected to the same installation together exceed a *rated power* of 11 kW in the *point of connection*. In that case, other technical regulations for network connection of *electricity-generation plants* of more than 11 kW apply.

Single-phase and two-phase *electricity-generation plants* with a *rated power* of more than 16 A per phase cannot be connected to the network without the prior written agreement with the *distribution network operator* on network connection and use of the network.

The regulation does not apply to requirements relating to *electricity-generation plants* used solely for emergency and reserve supply to an installation when such installation is not connected to the *public electricity supply network*.

The regulation does not deal with the financial aspects of settlement metering or the technical requirements in this connection.

### 2.4 Statutory authority

The regulation has been prepared in pursuance of section 26(1) of the Danish Electricity Supply (Consolidation) Act no. 516 of 20 May 2010 and in pursuance of section 7(1), paras 1, 3 and 4, of the Danish (Consolidation) Act no. 1463 of 19 December 2005 on Transmission System Operation and the Use of the Electricity Transmission Grid etc.

### 2.5 Commencement

This regulation comes into force on 1 January 2011.

Questions and requests for additional information can be directed to Energinet.dk, Front Office Electricity, [fo@energinet.dk](mailto:fo@energinet.dk).

The regulation was notified to the Danish Energy Regulatory Authority on 23 November 2010 in accordance with the provisions of section 76 of the Danish Electricity Supply Act and section 7 of the Danish Act on Transmission System Operation and the Use of the Electricity Transmission Grid etc.

### 2.6 Complaints

Any complaints in respect of this regulation must be lodged with the Danish Energy Regulatory Authority, Nyropsgade 30, DK-1780 Copenhagen V.

Complaints of the *transmission system operator's* enforcement of the provisions of the regulation can also be lodged with the Danish Energy Regulatory Authority.

Complaints of the individual *distribution network operator's* enforcement of the provisions of the regulation can be lodged with the *transmission system operator*. Complaints of the individual *distribution network operator's* enforcement of the provisions of the regulation can be lodged with the *transmission system operator*. A complaint lodged in respect of a *distribution*



*network operator* will always oblige the *transmission system operator* to ask the *distribution network operator* to comment on the complaint.

## 2.7 Non-compliance

It is the responsibility of the *plant owner* to ensure that the provisions of this regulation as well as the manufacturer's requirements and recommendations, see EN50438, chapter 6.5, are complied with throughout the useful life of the *electricity-generation plant*.

Unless otherwise expressly stated, expenses related to complying with the provisions of this regulation are the responsibility of the *plant owner*.

## 2.8 Sanctions

If an *electricity-generation plant* does not comply with the provisions of this regulation, the *distribution network operator* is entitled to cut off the electrical connection to the plant.

## 2.9 Exemptions and unforeseen events

The *transmission system operator* may grant exemption from specific requirements in the regulation.

An exemption can only be granted if:

- the deviation is not contrary to the intention of EN50438 regarding the harmonisation of the conditions for network connection applying to small *electricity-generation plants*
- special conditions prevail, for instance of local character
- the deviation does not appreciably impair the technical quality and balance of the *public electricity supply network*
- the deviation is not inappropriate from a socioeconomic viewpoint.

In order to obtain exemption, a written application must be submitted to the *distribution network operator*, indicating which provisions the exemption concerns and the reason for applying for the exemption. The *distribution network operator* has the right to comment on the application before it is submitted to the *transmission system operator*.

If events not foreseen in this regulation occur, the *transmission system operator* must decide what to do in consultation with the parties involved. If an agreement cannot be reached, the *transmission system operator* must decide what is to be done. The decision must be based on what is fair and equitable and, where possible, taking the views of the parties involved into consideration. Complaints of the decisions of the *transmission system operator* can be lodged with the Danish Energy Regulatory Authority, see **chapter 2.6**.

## 2.10 References

Reference is made to the following documents in the regulation:

1. EN50438:2007 'Requirements for connection of micro-generators in parallel with public low-voltage distribution networks', December 2007.
2. 'Fællesregulativet 2007' (*Joint Regulation*), Danish Energy Association, August 2007.
3. 'Stærkstrømsbekendtgørelsen' (*Danish Heavy Current Regulation*), section 6, executive order no. 12502 of 01/07/2001.
4. DEFU report RA498, 'Lavspændingsinstallationer med egenproduktion' report 498 (*Low-voltage installations with autogeneration*), November 2003.
5. EMC Directive 2004/108/EF of 15 December 2004 on electro-magnetic compatibility.

Danish titles of references made in EN 50438:

1. DS/EN50110 series, "Drift af elektriske anlæg", stærkstrømsbekendtgørelsen, afsnit 5.
2. DS/EN50160 "Karakteristika for spændingen i offentlige elektricitetsforsyningsnet".
3. DS/EN60664-1 "Isolationskoordinering for udstyr til lavspændingssystemer – Del 1: Principper, krav og prøvninger" (IEC60664-1).
4. DS/EN61000-3-2 "Elektromagnetisk kompatibilitet (EMC) – Del 3-2: Grænseværdier - Grænseværdier for udsendelse af harmoniske strømme (udstyrets strømforbrug op til og inklusive 16 A per fase)".
5. DS/EN61000-3-3 "Elektromagnetisk kompatibilitet (EMC) – Del 3-3: Grænseværdier – Begrænsning af spændingsændringer, spændingsfluktuationer og flimmer i offentlige lavspændingsforsyninger, fra udstyr med *mærkestrøm* op til og med 16 A pr. fase og ikke beregnet til betinget tilslutning" (IEC61000-3-3).
6. DS/EN61000-6-1 "Elektromagnetisk kompatibilitet (EMC) – Del 6-1: Generiske standarder – Immunitet for bolig-, erhvervs- og letindustrimiljøer" (IEC61000-6-1, mod.).
7. DS/EN61000-6-3:2001 "Elektromagnetisk kompatibilitet (EMC) – Del 6-3: Generiske standarder – Emissionsstandard for bolig-, erhvervs- og letindustrimiljøer" (IEC61000-6-3 Ed. 2.0).
8. EN61000-6-3 + A11 2004 "Elektromagnetisk kompatibilitet (EMC) – Del 6-3: Generiske standarder – Emissionsstandard for bolig, erhverv og let industrimiljøer" (IEC61000-6-3:1996, mod.).
9. HD 384 / EN60364 serie "Elektriske installationer i bygninger" (IEC 60364 series, mod.), stærkstrømsbekendtgørelsen, afsnit 6.

### 3. Installation requirements

#### 3.1 General

An *electricity-generation plant* and the installation hereof must comply with the requirements of the Danish Heavy Current Regulation and section 4.1 of EN50438.

#### 3.2 Over-current protection

An *electricity-generation plant* must be fitted with over-current protection in compliance with the Danish Heavy Current Regulation and section 4.1.2 of EN50438.

#### 3.3 Earthing

An *electricity-generation plant* must be earthed in compliance with section 6 of the Danish Heavy Current Regulation and section 4.1.3 of EN50438.

#### 3.4 Energy metering

Metering and settlement of electricity production must be performed in accordance with Energinet.dk's regulations. Note that correct electricity metering cannot be expected until the *distribution network operator* has verified the metered data.

#### 3.5 Rating plate

The *electricity-generation plant* must be fitted with a rating plate as specified in sections 6.3 and 6.4 of EN50438.

#### 3.6 External stop signal (available)

The *electricity-generation plant* must be prepared to receive an external stop or start signal.

The signal must be physically accessible via a terminal strip for receiving the analogue or digital signal, as shown in **Figure 2**.

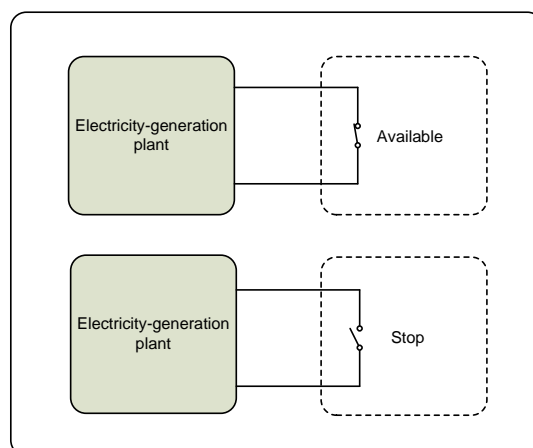

Figure 2 Possible exchange of external stop signal (available)

The *distribution network operator* must upon request be granted access to the *electricity-generation plant* to install communication equipment.

## 4. Network protection in the point of connection

### 4.1 General

The protection equipment must ensure that the *electricity-generation plant* neither impairs the *public electricity supply network* nor reduces the safety of personnel and equipment.

Protective functions for *electricity-generation plants* connected to the *public electricity supply grid* must be provided in accordance with the requirements in chapter 4.2.2 of EN50438, and Annex A, as stated in **Table 1**.

Protective function	Symbol	Setting <sup>a)</sup>	Function time
Overvoltage (stage 2) <sup>b)</sup>	$U_{>>}$	230 V+13%	0.2 s
Overvoltage (stage 1)	$U_{>}$	230 V+10%	40 s
Undervoltage (stage 1)	$U_{<}$	230 V-10%	10 s
Overfrequency	$f_{>}$	52.0 Hz	0.2 s
Underfrequency	$f_{<}$	47.5 Hz	0.2 s
"ROCOF" <sup>c)</sup>	df/dt	2.5 Hz/s	0.2 s

Table 1 Protective functions, operational settings and function times

<sup>a)</sup> <sup>a)</sup> All values are RMS values. The *electricity-generation plant* must be disconnected<sup>d</sup> or stop supplying power to the *public electricity supply network* if a metered value deviates from its nominal value by more than the setting. A metered value must not cause disconnection if it lies between the nominal value and the setting.

<sup>b)</sup> <sup>b)</sup> two-stage overvoltage protection is required if the *electricity-generation plant* is capable of generating voltages exceeding 230 V + 13%.

<sup>c)</sup> The use of vector jump relays as protection against *loss of mains* is not allowed.

<sup>d)</sup> Disconnection of an *electricity-generation plant* must be performed using electrical or insulated relay switches.

### 4.2 Frequency and voltage deviations

If the frequency or the voltage exceeds the limit values in **Table 1**, the *electricity-generation plant* is automatically disconnected from the *public electricity supply network*.

### 4.3 Detection of *loss of mains*

*Loss of mains* must result in the automatic disconnection of the main circuit for the *electricity-generation plant*. Detection of *loss of mains* must be performed using ROCOF (df/dt), as shown in **Table 1**.

#### **4.4 Reconnection after *loss of mains***

After *loss of mains*, it must not be possible for the *electricity-generation plant* to reconnect manually or automatically until the voltage and the frequency have been within the stationary limit values shown in **Table 1** for three minutes (mechanical AC installations) and 20 seconds (inverter-based installations), as specified in section 4.2.4 of EN50438.

#### **4.5 Synchronisation**

Synchronisation of the *electricity-generation plant* with the *public electricity supply network* must take place automatically in accordance with section 4.2.5 of EN50438.

## 5. Voltage quality

### 5.1 General

An *electricity-generation plant* must comply with the European EMC directive.

Wherever the EMC directive does not include specific product requirements, the general requirements of section 5.1 of EN50438 must be observed.

### 5.2 Voltage dips, flicker and overcurrents

The *electricity-generation plant* must comply with the requirements of section 5.1 of EN50438.

Furthermore, the inrush current may result in a voltage dip of maximum 4%, which is deemed to be the case if the current is lower than the current values shown in **Table 2** below.

Connection	Inrush current
Phase and zero	25 A
Three phases	40 A

Table 2 Highest inrush currents

### 5.3 DC injection from the facility

The *electricity-generation plant* must be designed not to supply DC current in normal operation in accordance with section 5.2 of EN50438.

This requirement is deemed as having been complied with when the *electricity-generation plant* fulfils the requirements for DC current provided by appliances, as specified in IEC 61000-3-2.

### 5.4 Power factor

Unless a special agreement to the contrary is made with the *distribution network operator*, the power factor ( $\cos \varphi$ ) for the *electricity-generation plant* must lie in the interval  $-0.95 \leq \cos \varphi \leq +0.95$  when generation constitutes more than 20% of the *rated power* and the voltage and the frequency lie within the stationary limit values shown in **Table 1**, see section 5.3 of EN50438.

## 6. Notification and documentation

### 6.1 Notification

According to the 'Joint Regulation' (*Fællesregulativet*) (in Danish only) and section 7.3.1 of EN50438, the *distribution network operator* must be notified if an *electricity-generation plant* is to be connected to the network and the amount of electricity to be supplied by an *electricity-generation plant* is changed. This must be done by a certified electrician before installation is commenced.

When an *electricity-generation plant* is connected to the network, and such connection does not require the prior consent of the *distribution network operator*, an agreement must be made with the *distribution network operator* on network connection and network protection not later than 30 days after commissioning of the *electricity-generation plant*.

The *electricity-generation plant* must be type-tested according to the product-specific standard. If the product-specific standard does not prescribe a type test, the *electricity-generation plant* must be tested in accordance with EN50438.

Notification of a type-tested *electricity-generation plant* can be made when notification of the *electricity-generation plant* is made, see the 'Joint Regulation' (*Fællesregulativet*) (in Danish only).

#### 6.1.1 Stand-alone units

The procedure for installing stand-alone units must comply with the requirements of section 7.3.1 of EN50438.

The documentation must comply with the requirements of **section 6.2.1**.

#### 6.1.2 Multiple/planned units

The procedure for installing multiple or planned units must comply with the requirements of section 7.3.2 of EN50438.

The documentation must comply with the requirements of **section 6.2.2**.

Examples of multiple/planned units:

- Construction projects where several small *electricity-generation plants* are into the project
- Planned replacement of several gas burners in CHP plants in a particular area.

## 6.2 Documentation

The supplier is responsible for ensuring that the *electricity-generation plant* complies with this technical regulation and providing documentation to this effect.

The supplier is responsible for providing documentation to the effect that this technical regulation has been complied with and must as such prepare a supplier statement, see **Appendix B1.2**.

The general procedure regarding the approval and issue of operating permits for an *electricity-generation plant* is as follows:

- A certified electrician provides the documentation outlined in **chapter 6.2.1** or **chapter 6.2.2**.
- A certified electrician sends the documentation electronically to the *distribution network operator*.
- The *distribution network operator* reviews and approves the documentation and determines whether all information has been provided. When the documentation has been approved, an operating permit will be issued to the *plant owner*.
- The *distribution network operator* sends the approved documentation electronically to Energinet.dk's Front Office Electricity at [fo@energinet.dk](mailto:fo@energinet.dk).

### 6.2.1 Stand-alone units (type-tested)

According to the Joint Regulation, a certified electrician must submit a notification form to the *distribution network operator* before the network connection of an *electricity-generation plant* which does not require the prior consent of the *distribution network operator*.

The documentation to be provided must be in the form of data valid at the time of commissioning:

- General, see **Appendix B1.1**
- Technical documentation, see **Appendix B1.2**

All documentation must have been received by the *distribution network operator* **not later than 30 days after commissioning** of the *electricity-generation plant*.

### 6.2.2 Multiple/planned units

According to the Joint Regulation, a certified electrician must submit a notification form to the *distribution network operator* before the network connection of an *electricity-generation plant* which requires the prior consent of the *distribution network operator*.

The documentation to be provided must be in the form of data valid at the time of commissioning:

- General, see **Appendix B1.1**
- Technical documentation, see **Appendix B1.2**
- For multiple plants, a project description providing relevant information about network connection must be enclosed



The documentation must be sent to and approved by the *distribution network operator* **before commissioning** of the *electricity-generation plant*.

### **6.3 Decommissioning**

When an *electricity-generation plant* is decommissioned, the *distribution network operator's* standard procedure must be observed.

### **6.4 Modification or replacement**

According to section 7.5 of EN50438, the *distribution network operator* must be informed when main components are to be replaced or modified or when protective settings are to be altered.

When an *electricity-generation plant* is to be replaced, the replaced plant must be decommissioned as described in **chapter 6.3**. The new plant must then be notified to the *distribution network operator* as described in **chapter 6.1**.

## Appendix 1. Documentation

Appendix 1 describes the total documentation requirement for an *electricity-generation plant*. Appendix 1 must be filled in and sent electronically to the *distribution network operator*.

**Appendix B1.1** outlines the general information to be provided for an *electricity-generation plant*. The information will be used by the *distribution network operator* to register and set up an *electricity-generation plant* in the electronic Self-service portal.

A template for **Appendix B1.1** can be found at [www.energinet.dk](http://www.energinet.dk).

**Appendix B1.2** Technical documentation comprises the information necessary in order for the *distribution network operator* to approve the *electricity-generation plant*.

A template for test report **Appendix B1.2.4** (see EN 50438 Annex D) can be found at [www.energinet.dk](http://www.energinet.dk).

**B1.1. General**

Description	Text
<b><i>Plant owner:</i></b>	
CVR no.	
or CPR (civil registration no.)	
Company name	
Contact person (administrative)	
Street	
House no.	
Postal code	
City/town	
Telephone no.	
Email:	
<b><i>Plant address:</i></b>	
Contact person (technical)	
Street	
House no.	
Postal code	
City/town	
Telephone no.	
BBR municipality	
X/Y coordinates	
Title no.	
Owners' association on titled land	
<b><i>BBR information:</i></b>	
BBR municipality no.	
BBR property no.	
BBR building	

Description	Text
<b>Identification:</b>	
Name of <i>distribution network operator</i>	
Short name	
Plant name	
Installation no.	
Ediel no.	
GSRN number	
P-unit	
Plant type (PV, wind turbine, other)	
<b>Operational data:</b>	
Planned commissioning	
Commission date, first kWh	
Electricity trader	
Balance-responsible party	
Metering point administrator	
<b>Technical data for wind turbine:</b>	
Manufacturer	
Type designation (model)	
Type approval	
Approval authority	
Installed kW (rated power)	
No. of phases	
Short-circuit current immediately in front of wind power plant (RMS)	
Rotor diameter (m)	
Hub height (m)	
Point of connection	
Voltage level	

Description	Text
<b>Technical data for PV cell plants or other plant types:</b>	
Plant type	
Manufacturer	
Type designation (model)	
Type approval	
Approval authority	
Installed kW (rated power)	
No. of phases	
Short-circuit current immediately in front of plant (RMS)	
Point of connection	
Voltage level	

#### Declaration by certified electrician

<b>Comments:</b>		
<b>Notification:</b> I hereby declare that the installation has been dimensioned and carried out in accordance with the provisions of the Danish Heavy Current Regulation and the instructions issued by the supplier regarding network connection of the <i>electricity-generation plant</i> .		Yes <input type="checkbox"/> No <input type="checkbox"/>
<b>Name:</b>	<b>Signature:</b>	<b>Date:</b>

## **B1.2. Technical documentation**

### **B1.2.1. Supplier statement**

The supplier statement documents that the requirements in Grid Code 3.2.1 are complied with.

The supplier statement must be supplemented with the relevant appendices described in **Appendix B1.2.2** to **Appendix B1.2.4**.

### **B1.2.2. Process diagram of the electricity-generation plant**

The appendix outlines the components and control equipment for the *electricity-generation plant* up to and including the *point of connection*. The diagram must show how protective functions and external stop signal have been implemented.

### **B1.2.3. Type approval**

This only applies to *wind turbines*.

Documentation for approval and registration with the approval secretariat under the Danish Energy Agency must be enclosed.

For wind turbines with a rotor area of up to 5 m<sup>2</sup> the notification replaces the type approval.

### **B1.2.4. Test report**

This applies to *electricity-generation plants* with or without inverters that have been type-tested in accordance with TF 3.2.1 or the underlying European standard EN 50438.

Documentation for compliance with the voltage quality requirements in **chapter 5** must be provided, see **EN 50438, Annex D**.

## Appendix 2. Earlier provisions

Below follows an overview of the previous provisions and recommendations applying to *thermal power station units*. Existing plants commissioned before this regulation came into force are subject to the previous provisions and recommendations.

For power station units in the West Danish area (Jutland and Funen):

- 1995-2006: 'Kraftværksspecifikationer for produktionsanlæg mindre end 2 MW', (*Power station specifications for generating facilities under 2 MW*), memorandum NP91/SP-515h, Elsam, 1995.

For power station units in the East Danish area (Zealand and islands):

- 1990-1995: 'Driftstekniske specifikationer for mindre varmekraft anlæg, Tillæg nr. 1', (*Operational performance specifications for small-scale CHP plants, amendment no. 1*), Nordel, August 1990.
- 1995-2004: 'Operational Performance Specifications for Small Thermal Power Units, Amendment no. 1', Nordel, 1995.
- 1999-2006: 'Standardvilkår for nettilslutning af lokale kraftvarmeanlæg mindre end 25 MW' (*Standard terms for grid connection of local CHP plants smaller than 25 MW*), Sjællandssamarbejdet, 1999.

Harmonised document for the entire Danish area:

- 2003-2007: 'Lavspændingsinstallationer med egenproduktion – Retningslinjer for nettilslutning af produktionsanlæg', (*Low-voltage installations with autogeneration – Guidelines for grid connection of production plants*), prepared for ELFOR, Eltra and Elkraft, DEFU report RA498, November 2003.